



AIR SOURCE HEATING HEAT PUMP UNIT

INSTALLATION MANUAL

KFXFC-009SCI, DKFXF-009SCI, DKFXFC-014SCI, DKFXF-014SCI, KFXFC-018SCI/C,
DKFXFC-018SCI/C, KFXFC-017SCII, KFXF-017SCII, DKFXFC-017SCII, DKFXF-017SCII,
KFXF-018SCI, KFXFC-021SPCI, KFXFC-028UCII, KFXF-028UCII, KFXFC-032UCII, KFXF-032UCII,
KFXFC-032SCII, KFXFC-065UCII, KFXFC-075UCII, KFXF-065UCII, KFXF-075UCII

- ◆ Please read this manual carefully before using this product.
- ◆ Please keep this manual for future reference.

AIR SOURCE HEATING HEAT PUMP INSTALLATION MANUAL

Dear user:

Thank you for using our products!

You are using an air source heat pump unit. There are certain requirements for the installation, use and maintenance of the unit. Properly installed, used, and maintained, your hot water unit will have a reduced failure rate and a significant increase in service life.

At the same time, correct installation, use, and maintenance will reduce the failure rate of your hot water unit and increase its service life.

We are always committed to technical improvements, please do drain the water from the system to avoid freezing the system.

Foshan Airosd Thermal Technology Co.,Ltd

Please keep it well for further reference.

If there are mistakes and omissions, please criticize and correct them.

CONTENTS

CHAPTER I INTRODUCTION.....	1
1.1 TYPE & MODEL.....	1
1.2 NAMING RULE.....	1
1.3 COMPONENTS.....	1
1.4 SCHEMATIC DIAGRAM OF SYSTEMS.....	2
1.4.1 COOLING OPERATION.....	2
1.4.2 HEATING OPERATION.....	2
1.4.3 DEFROST OPERATION.....	3
1.5 PERFORMANCE PARAMETERS.....	4
1.6 ENVIRONMENTAL REQUIREMENTS.....	8
1.6.1 OPERATING ENVIRONMENT.....	8
1.6.2 STORAGE ENVIRONMENT.....	8
1.6.3 ANTIFREEZE WARNING.....	8
CHAPTER II HEAT PUMP INSTALLATION.....	9
2.1 EQUIPMENT HANDLING, UNPACKING, INSPECTION.....	9
2.1.1 TRANSPORTATION & HANDLING.....	9
2.1.2 UNPACKING.....	10
2.1.3 INSPECTIONG.....	10
2.2 SAFETY RULES.....	10
2.3 SAFETY PRECAUTIONS.....	11
2.4 SELECTION OF INSTALLATION SITES.....	11
2.5 REQUIREMENTS FOR THE ARRANGEMENT SPACING OF THE UNITS.....	12
2.6 SYSTEM INSTALLATION LAYOUT.....	12
2.6.1 OVERALL LAYOUT OF THE HYDRAULIC SYSTEM.....	12
2.6.2 COMMERCIAL UNIT APPLICATION HYDRAULIC SYSTEM DIAGRAM.....	14
2.6.3 MINIMUM CAPACITY OF THE WATER SYSTEM.....	15
2.6.4 MECHANICAL PARAMETERS.....	16
2.7 INSTALLATION OF THE UNIT.....	20
2.7.1 NSTALLATION SPACE.....	20
2.7.2 MAINTENANCE SPACE REQUIREMENTS.....	20
2.7.3 INSTALLATION STEPS.....	20
2.8 INSTALLATION BASIC REQUIREMENTS.....	22
2.9 INSTALLATION OF THE UNIT PIPING.....	23
2.9.1 ABOUT CONNECTING THE UNIT WATER SYSTEM PIPING.....	23
2.10 INSPECTION ITEMS AFTER MECHANICAL INSTALLATION IS COMPLETED.....	23
CHAPTER III ELECTRICAL INSTALLATION.....	24
3.1 TASK INTRODUCTION AND PRECAUTIONS.....	24
3.1.1 POWER SPECIFICATIONS.....	25
3.2 UNIT WIRING.....	25
3.2.1 WIRING REQUIREMENTS.....	25
3.3 PAY ATTENTION TO THE INSTALLATION CHECK.....	26
3.4 SWITCH OF GROUND HEATING PANEL WIRES.....	26
3.5 MODULE UNIT WIRING.....	27
3.5.1 MOTHERBOARD SECTION.....	27
CHAPTER IV SYSTEM TEST RUN.....	28
4.1 IMPORTANT INFORMATION OF TEST RUN.....	28

4.2 POST-INSTALLATION CHECK ITEM LIST.....	28
4.3 TEST RUN.....	29
CHAPTER V OPERATING INSTRUCTION.....	30
5.1 DIGITAL THERMOSTAT OPERATION.....	30
5.1.1 HIGH, MID, LOW.....	30
5.1.2 COOLING, HEATING, FAN, HOT WATER.....	30
5.1.3 COMP. 1, COMP. 2. 	31
5.1.4 FAULT.....	31
5.1.5 CHECK.....	31
5.1.6 SETTING.....	31
5.1.7 CENTRAL CONTROL.....	32
5.1.8 MAIN DISPLAY.....	32
5.1.9 TIMING ON & TIMING OFF.....	32
5.1.10 SUB DISPLAY.....	32
5.1.11 FANS & PUMPS.....	32
5.2 FUNCTIONAL OPERATION INSTRUCTIONS.....	32
5.2.1 ON/OFF.....	32
5.2.2 WATER SUPPLY.....	32
5.2.3 WATER TEMPERATURE SETTING.....	32
5.2.4 TIMING.....	32
5.2.5 TIME.....	33
5.2.6 PARAMETER QUERY.....	33
5.2.7 FUNCTION.....	33
5.2.8 CENTRALIZED CONTROL DESCRIPTION.....	36
CHAPTER VI SYSTEM OPERATION AND MAINTENANCE.....	37
6.1 SYSTEM DIAGNOSTIC TEST.....	37
6.1.1 ELECTRONIC CONTROL PART.....	37
6.2 COOLIING SYSTEM.....	37
6.2.1 PLATE HEAT EXCHANGER.....	37
6.2.2 COMPRESSOR REPLACEMENT.....	38
CHAPTER VII FAULT FINDING and REMEDIES.....	40

CHAPTER I INTRODUCTION

This chapter mainly introduces the classification and model, naming rules, main components, working principle, transportation and storage environment requirements of air source heat pump heating and cooling units (hereinafter referred to as "units").

1.1 TYPE & MODEL

This series is including two types –Low temperature heating units & Low temperature heating and cooling units

1.2 NAMING RULE

Take KFXFC-009SEI as an example, the naming rule is shown as Figure 1-1.

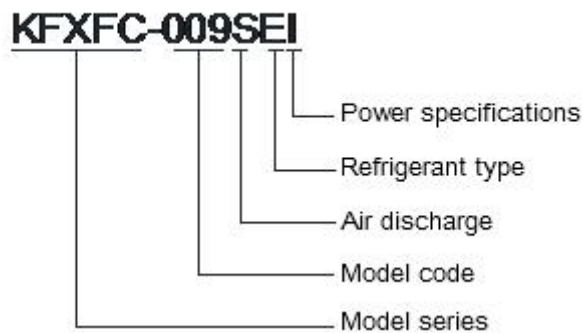

Figure 1- 1 Naming Rule

Power specifications: I:220V/1N~/50Hz; II: 380V/3N~/50Hz;

Refrigerant type: E: R404a; Vacancy: R22; C:R407C;

Model code: generally named after the unit heating capacity (kW)

Model series: KFXFC: Air source heat pump cooling & heating unit

1.3 COMPONENTS

The unit includes compressors, finned tube heat exchangers, fans, controllers, expansion valves, plate heat exchangers, etc.

Compressor

Using high-efficiency scroll compressors, some models of it with EVI function; low vibration, low noise and high reliability.

Finned tube heat exchangers

Using finned tube heat exchanger with high heat dissipation efficiency. Design and verification of the distributor for specific models to ensure uniformity of refrigerant distribution in each circuit, greatly improving the utilization of heat exchangers.

Plate heat exchanger

Using brazed plate heat exchanger, which has characteristics of compact structure and high heat exchange efficiency.

Flow switch

Using brand-name products, which with high reliability, and can effectively protect the unit.

1.4 SCHEMATIC DIAGRAM OF SYSTEMS

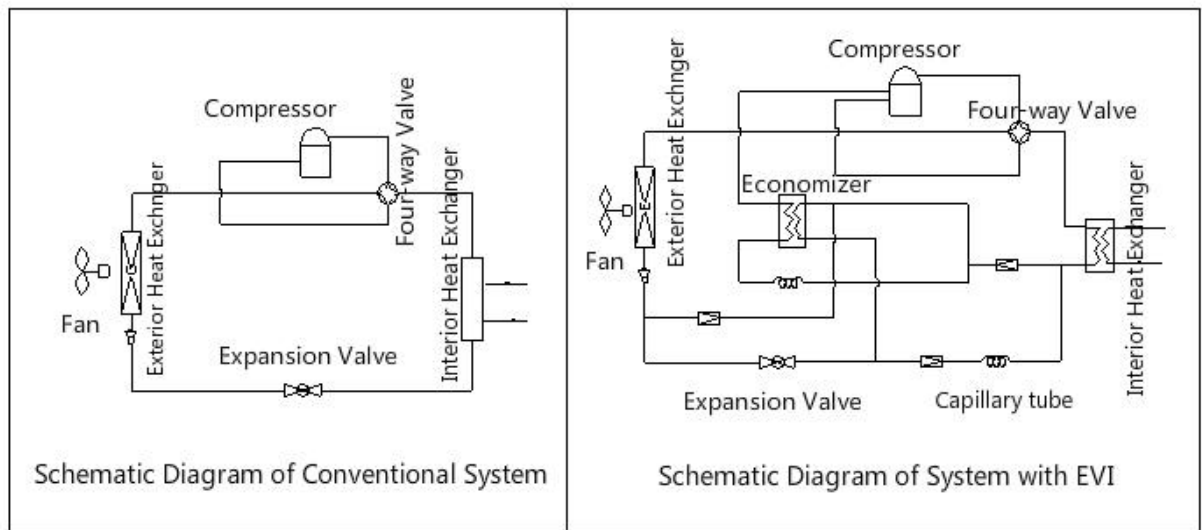

Figure 1- 2 Schematic Diagram of Systems

1.4.1 COOLING OPERATION

1. After compression by the compressor, the low-temperature low-pressure gaseous refrigerant becomes a high-temperature high-pressure gaseous refrigerant. After being discharged from the compressor exhaust pipe, it enters the condenser (air-side heat exchanger) through the four-way reversing valve. As the fan operates, the heat is carried away so that the refrigerant is condensed and becomes a liquid refrigerant.
2. The high pressure liquid refrigerant that has been condensed by the condenser enters the expansion valve. The liquid refrigerant expands in volume after throttling, and the state changes to become a low-temperature, low-pressure liquid refrigerant and a part of the gaseous refrigerant.
3. The gas-liquid mixture of the refrigerant flows into the evaporator (water-side heat exchanger) through the pipeline, and the refrigerant expands and evaporates in the heat exchanger, absorbs heat in the water, evaporates and absorbs heat to become gaseous, and the temperature of the brine becomes low. The pump is continuously operate, and the cooling capacity is continuously pumpe to the end equipment, and then the cooling capacity is emitted.
4. Finally, the gaseous refrigerant that has been expanded and evaporated passes through the four-way reversing valve and the compressor suction line to enter the compressor then compress again and the cycle is repeated.

1.4.2 HEATING OPERATION

1. The working fluid, in its gaseous state, is pressurized and circulated through the system by a compressor, and then go into the heat exchanger through the fore-way reversing valve. The unit to release heat though the water, and the refrigerant is condensed into a high pressure liquid.
2. The high pressure liquid refrigerant that has been condensed by the condenser enters the expansion valve. The liquid refrigerant expands and changes state after throttling, and becomes a low-temperature, low-pressure liquid refrigerant and a part of the gaseous refrigerant.
3. After passing through the pipeline, the liquid refrigerant evaporates and absorbs the heat of the air in the air-side heat exchanger to become a gaseous refrigerant.

4. Finally, the gaseous refrigerant enters the compressor through the four-way reversing valve and the compressor suction line then compress again and the cycle is repeated.

1.4.3 DEFROST OPERATION

1. When the unit is running in the heating mode in a low ambient temperature, the air side heat exchanger may frost, which will affect the heating effect, so defrosting is required.
2. The defrost controller performs long-term monitoring by combining the air side coil temperature and the timer to determine whether defrosting is required.
3. The unit changes the heating operation to the cooling operation through the four-way reversing valve. At this moment, the high-temperature and high-pressure gaseous refrigerant is defrost through the air side heat exchanger. The fan does not operate during the defrost time of the compressor.
4. After the defrosting is completed, the cooling operation is resumed to the normal state - heating operation by switching the four-way switching valve.

1.5 PERFORMANCE PARAMETERS

MODEL			KFXFC-009SCI	DKFXF-009SCI	DKFXFC-014SCI	DKFXF-014SCI	KFXFC-018SCI/C	DKFXFC-018SCI/C
VOLTAGE/FREQUENCY			220V 1N~ /50Hz				220V 1N~ /50Hz	
RATED COOLING a	COOLING CAPACITY	kW	7.50	/	11.5	/	14.5	/
	POWER INPUT	kW	2.60	/	3.83	/	5.18	/
	EER	/	2.81	/	2.8	/	2.81	/
	OPERATING CURRENT	A	12.5	/	18.7	/	22.2	/
RATED HEATING b	HEATING CAPACITY	kW	8.7	8.7	14.4	14.5	11.0	17.2
	POWER INPUT	kW	3.3	2.64	4.07	4.07	4.78	4.85
	COP	/	3.56	3.56	3.6	3.56	2.30	3.5
	OPERATING CURRENT	A	11.1	11.1	19.5	19.5	22.2	22.8
LOW TEMPERATURE HEATING c	HEATING CAPACITY	kW	5.3	5.3	9.10	9.10	10.5	10.5
	POWER INPUT	kW	2.30	2.30	3.87	3.87	4.57	4.57
	COP	/	2.31	2.31	2.2	2.35	2.31	2.31
A7W35 ^d		kW/COP	9.4/4.1	9.4/4.1	14.5/4.4	14.5/4.4	17.2/4.3	17.2/4.3
A-7W55		kW/COP	6.3/2.6	6.3/2.6	9.7/2.6	9.7/2.6	11.0/2.6	11.0/2.6
A-15W35		kW/COP	5.3/2.7	5.3/2.7	8.1/2.1	8.1/2.1	8.8/2.1	8.8/2.1
A-20W45		kW/COP	4.6/2.1	4.6/2.1	7.5/2.0	7.5/2.0	7.5/2.0	7.5/2.0
MAX. OPERATING CURRENT		A	18		30		38.5	
COMPRESSOR	TYPE	/	EVI					
	QUANTITY	Unit	1					
REFRIGERANT TYPE/WEIGHT		/	R407C/2200g		R407C/4400g		R407C/5000g	
AIR DISCHARGE		/	SIDE					
WATER INLET SIZE		inch	G1" female thread		G1.2" female thread		G1" female thread	
STATED CURRENT		m ³ /h	1.2/1.6		2.0		2.5	
WATER PRESSURE LOSS		kPa	≤20		≤40		≤45	
NOISE LEVEL		dB(A)	≤56		≤63		≤59	
DIMENSION (L*D*H)		mm	1090×435×900		1120×440×1360		1120×440×1360	
NET WEIGHT		kg	80		150		160	
a: Rated cooling working conditions: ambient temperature 35 °C, inlet water temperature 12 °C, outlet water temperature 7 °C;								
b: Rated heating working conditions: ambient dry bulb temperature 7 °C, wet bulb temperature 6 °C, inlet water temperature 40 °C, outlet water temperature 45 °C;								
c: Low temperature heating working conditions: ambient dry bulb temperature -12 °C, wet bulb temperature -14 °C, outlet water temperature 41 °C;								
d: A7W35 working conditions: inlet air temperature 7 °C, water outlet temperature 35 °C.								
If the product specification changes due to improvement, please refer to the unit rating plate.								

MODEL			KFXFC-017SCII	KFXF-017SCII	DKFXFC-017SCII	DKFXF-017SCII	KFXF-018SCI
VOLTAGE/FREQUENCY			380V /3N~ /50Hz				220V /1N~ /50Hz
RATED COOLING ^a	COOLING CAPACITY	kW	14.0	/	13.5	/	/
	POWER INPUT	kW	4.7	/	4.8	/	/
	EEROR	/	3.0	/	2.8	/	/
	OPERATING CURENT	A	8.5	/	8.6	/	/
RATED HEATING ^b	HEATING CAPACITY	kW	16.3	16.3	16.3	16.3	16.8
	POWER INPUT	kW	4.5	4.5	4.5	4.5	4.67
	COP	/	3.6	3.6	3.6	3.6	3.6
	OPERATING CURENT	A	8.0	8.0	8.0	8.0	21.5
LOW TEMPERATU RE HEATING ^c	HEATING CAPACITY	kW	9.8	9.8	9.8	9.8	10.6
	POWER INPUT	kW	3.8	3.8	3.8	3.8	4.1
	COP	/	2.6	2.6	2.6	2.6	2.6
A7W35 ^d		kW/COP	16.5/4.3	16.5/4.3	16.5/4.3	16.5/4.3	17.2/4.3
A7W55		kW/COP	15.9/3.0	15.9/3.0	15.9/3.0	15.9/3.0	16.5/3.0
A-7W45		kW/COP	11.3/2.7	11.3/2.7	11.4/2.7	11.4/2.7	12.6/2.6
A-15W45		kW/COP	8.8/2.2	8.8/2.2	9.5/2.2	9.5/2.2	9.5/2.2
A-20W45		kW/COP	7.9/2.0	7.9/2.0	8.2/2.0	8.2/2.0	8.6/1.9
MAX. OPERATING CURENT		A	14				36
COMPROSOR	TYPE	/	EVI				Scroll
	QUANTITY	Unit	1				2
REFRIGERANT TYPE/WEIGHT		/	R407C/4200g		R407C/4000g		R407C/2700g×2
AIR DISCHARGE		/	Side				
WATER INLET SIZE		inch	G1.2" female thread		G1.0" female thread		G1" female thread
STATED CURRENT	COOLING	m³/h	2.4	/	2.3	/	/
	HEATING	m³/h	2.8	2.8	2.8	2.8	2.5
WATER PRESSURE LOSS		kPa	≤20	≤20	≤60	≤60	≤60
NOISE LEVEL		dB(A)	≤57	≤57	≤58	≤58	≤58
DIMENSION (L*D*H)		mm	1087×435×1346		1060×440×1280		1120×440×1360
NET WEIGHT		kg	150		150		180

a: Rated cooling working conditions: ambient temperature 35 °C, inlet water temperature 12 °C, outlet water temperature 7 °C;

b: Rated heating working conditions: ambient dry bulb temperature 7 °C, wet bulb temperature 6 °C, inlet water temperature 40 °C, outlet water temperature 45 °C;

c: Low temperature heating working conditions: ambient dry bulb temperature -12 °C, wet bulb temperature -14 °C, outlet water temperature 41 °C;

d: A7W35 working conditions: inlet air temperature 7 °C, water outlet temperature 35 °C.

If the product specification changes due to improvement, please refer to the unit rating plate.

MODEL			KFXFC-021SPCI	KFXFC-028UCII	KFXF-028UCII	KFXFC-032UCII	KFXF-032UCII	KFXFC-032SCII
VOLTAGE/FREQUENCY			220V ~ /50Hz	380V /3N~ /50Hz				
RATED COOLING ^a	COOLING CAPACITY	kW	17.5	24	/	27	/	25
	POWER INPUT	kW	6.15	8.6	/	9.6	/	8.9
	EEROR	/	2.8	2.8	/	2.8	/	2.8
	OPERATING CURENT	A	28	15.6	/	17	/	16
RATED HEATING ^b	HEATING CAPACITY	kW	20.5	28.5	28.5	32	32	30.5
	POWER INPUT	kW	5.7	7.7	7.7	8.6	8.6	8.7
	COP	/	3.6	3.7	3.8	3.7	3.7	3.5
	OPERATING CURENT	A	26	8	8	15.5	15.5	15.5
LOW TEMPERAT URE HEATING ^c	HEATING CAPACITY	kW	12.5	19	19	21.3	21.3	20.4
	POWER INPUT	kW	5.4	7.3	7.3	8.2	8.2	8.2
	COP	/	2.3	2.6	2.6	2.6	2.6	2.5
A7W35 ^d		kW/COP	20.8/4.3	29.6/4.4	29.6/4.4	33.0/4.3	33.0/4.3	31.5/4.0
A7W55		kW/COP	20.0/3.0	27.5/3.0	27.5/3.0	30.2/3.0	30.2/3.0	30.2/3.0
A-7W45		kW/COP	15.6/2.6	20.3/2.7	20.3/2.7	22.8/2.7	22.8/2.7	21.9/2.6
A-15W45		kW/COP	11.9/2.2	16.8/2.3	16.8/2.3	18.2/2.2	18.2/2.2	17.3/2.1
A-20W45		kW/COP	10.5/2.0	14.4/2.0	14.4/2.0	16.2/2.0	16.2/2.0	15.4/1.9
MAX. OPERATING CURENT		A	45	23		25		
COMPROSOR	TYPE	/	EVI					
	QUANTITY	Unit	2	1		2		
REFRIGERANT TYPE/WEIGHT		/	R407C/3.0 kg*2	R407C/10kg		R407C/4000g		R407C/4.7 kg*2
AIR DISCHARGE		/	Side	Up				Side
WATER INLET SIZE		inch	G1.0" female thread	G1.5" female thread		G1.5" female thread		R1.2" male thread
STATED CURRENT	COOLING	m³/h	3.0	4.1	4.1	4.6	/	4.3
	HEATING	m³/h	3.5	4.9	4.9	5.5	5.5	5.2
WATER PRESSURE LOSS		kPa	≤45	≤50	≤50	≤60	≤60	≤30
NOISE LEVEL		dB(A)	≤65	≤67	≤67	≤68	≤68	≤68
DIMENSION (L*D*H)		mm	1355×535×1346	1500×750×1070		1500×750×1370		1400×810×1800
NET WEIGHT		kg	200	300		330		350
a: Rated cooling working conditions: ambient temperature 35 °C, inlet water temperature 12 °C, outlet water temperature 7 °C;								
b: Rated heating working conditions: ambient dry bulb temperature 7 °C, wet bulb temperature 6 °C, inlet water temperature 40 °C, outlet water temperature 45 °C;								
c: Low temperature heating working conditions: ambient dry bulb temperature -12 °C, wet bulb temperature -14 °C, outlet water temperature 41 °C;								
d: A7W35 working conditions: inlet air temperature 7 °C, water outlet temperature 35 °C.								
If the product specification changes due to improvement, please refer to the unit rating plate.								

MODEL			KFXFC-		KFXF-	
			065UCII	075UCII	065UCII	075UCII
VOLTAGE/FREQUENCY			380V /3N~ /50Hz			
RATED COOLING a	COOLING CAPACITY	kW	53.0	65.0	/	/
	POWER INPUT	kW	17.6	20.7	/	/
	EEROR	/	3.0	3.1	/	/
	OPERATING CURENT	A	31.5	37.0	/	/
RATED HEATING b	HEATING CAPACITY	kW	63.0	73.0	63.0	73.0
	POWER INPUT	kW	16.6	19.2	16.6	18.7
	COP	/	3.8	3.8	3.8	3.9
	OPERATING CURENT	A	30.2	34.5	30.2	33.5
LOW TEMPERATURE HEATING ° c	HEATING CAPACITY	kW	37.5	43.7	37.5	43.5
	POWER INPUT	kW	13.9	16.2	13.9	16.1
	COP	/	2.7	2.7	2.7	2.7
A7W35 ^d		kW/COP	65.0/4.5	75.0/4.5	65.0/4.5	75.0/4.4
A7W55		kW/COP	62.0/3.0	72.0/3.0	62.0/3.0	72.0/3.0
A-7W45		kW/COP	42.5/2.7	48.5/2.7	42.5/2.7	48.6/2.7
A-15W45		kW/COP	36.5/2.4	40.0/2.4	36.5/2.4	40.1/2.4
A-20W45		kW/COP	30.2/2.0	33.0/2.0	30.2/2.0	33.2/2.0
MAX. OPERATING CURENT		A	47	55	47	55
COMPROSOR	TYPE	/	EVI			
	QUANTITY	Units	2			
REFRIGERANT TYPE/WEIGHT		/	R407C/12kg	R407C/15kg	R407C/8.5kg	R407C/10kg
AIR DISCHARGE		/	UP			
WATER INLET SIZE		inch	DN50		DN100	
STATED CURRENT	COOLING	m ³ /h	9.1	10.6	/	/
	HEATING	m ³ /h	10.8	12.6	10.8	12.6
WATER PRESSURE LOSS		kPa	≤40	≤40	≤60	≤60
NOISE LEVEL		dB(A)	≤68	≤68	≤68	≤68
DIMENSION (L*D*H)		mm	2100×1100×2000		2100×1100×2100	
NET WEIGHT		kg	850	950	850	950
a: Rated cooling working conditions: ambient temperature 35 ° C, inlet water temperature 12 ° C, outlet water temperature 7 ° C;						
b: Rated heating working conditions: ambient dry bulb temperature 7 ° C, wet bulb temperature 6 ° C, inlet water temperature 40 ° C, outlet water temperature 45 ° C;						
c: Low temperature heating working conditions: ambient dry bulb temperature -12 ° C, wet bulb temperature -14 ° C, outlet water temperature 41 ° C;						
d: A7W35 working conditions: inlet air temperature 7 ° C, water outlet temperature 35 ° C.						
If the product specification changes due to improvement, please refer to the unit rating plate.						

1.6 ENVIRONMENTAL REQUIREMENTS

1.6.1 OPERATING ENVIRONMENT

The operating environment requirements of the unit are shown in Table 1-1.

Table 1-1 Operating environment requirements

ITEM	REQUIREMENT
INSTALLATION LOCATION	Installation method: horizontal installation
AMBIENT TEMPERATURE	Outdoor: -25 °C ~ +43 °C
ENVIRONMENT HUMIDITY	Outdoor: 5%RH~95%RH
RUNNING POWER	220V±10%/1N~/50Hz; 380V±10%/3N~/50Hz;
ALTITUDE	Not more than 1000m. Need to reduce the rated power when more than 1000m.
WATER PROOF RATING	IPX4

1.6.2 STORAGE ENVIRONMENT

The storage environment requirements of the unit are shown in Table 1-2.

Table 1-2 Storage environment requirements

ITEM	REQUIREMENT
STORAGE ENVIRONMENT	Indoor, clean place (no dust, etc.)
ENVIRONMENT HUMIDITY	5%~85% (no condensation)
AMBIENT TEMPERATURE	- 30 °C~+54 °C

1.6.3 ANTIFREEZE WARNING

When the ambient temperature of the unit is lower than 0 °C, please ensure that the unit is in the power supply state, if the antifreeze is not used as the cold carrier (heat) agent; If it cannot be ensured, please drain the water in the unit, otherwise the unit will have the risk of cracking. Each unit is equipped with drain valves at the lowest part of the unit's waterway.

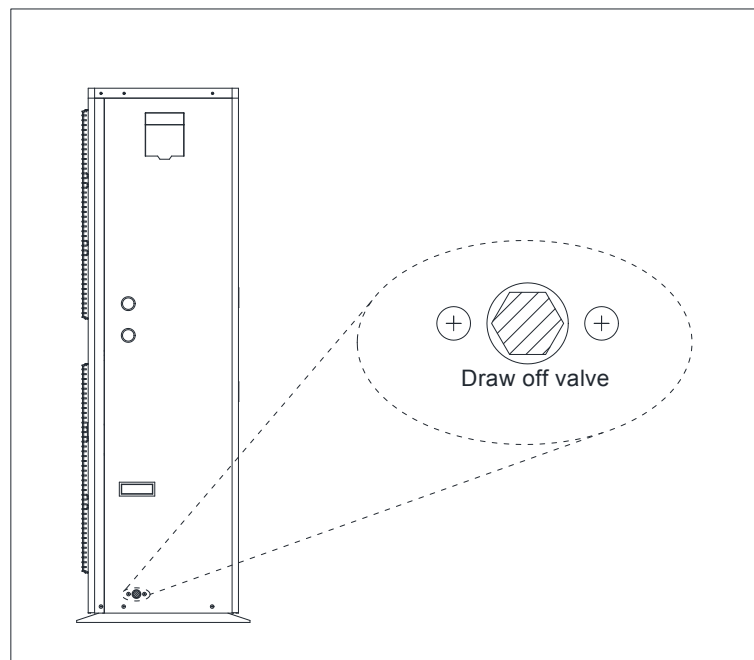

Figure 1- 3 Schematic Diagram of drain valve position

CHAPTER II HEAT PUMP INSTALLATION

This chapter describes the mechanical installation of the unit, including transportation, unpacking inspection, installation layout, and installation procedures, etc.

2.1 EQUIPMENT HANDLING, UNPACKING, INSPECTION

2.1.1 TRANSPORTATION & HANDLING

Choose a road with better conditions to prevent excessive bumps when transporting.

The tilt angle of the unit should be kept within the range of $75^{\circ} \sim 105^{\circ}$ when transporting. (Figure 2-1)

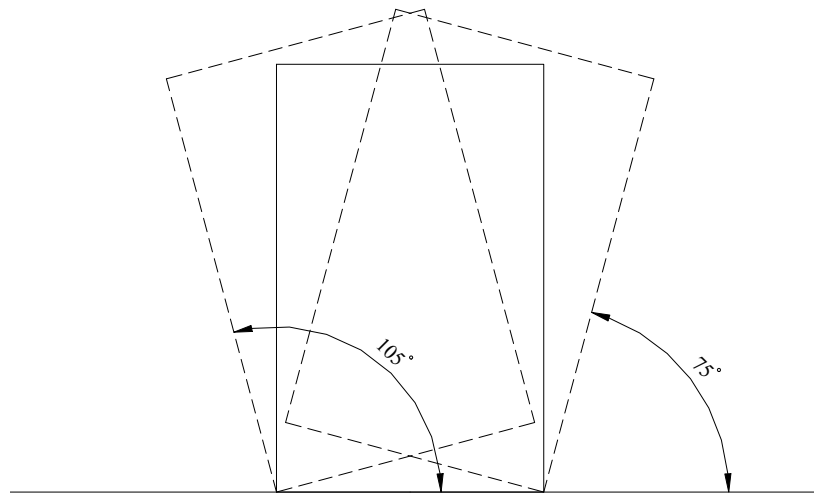

Figure 2- 1 The tilt angle of the unit

Please use a forklift to carry it. If there is no forklift, please move it with the help of the cylinder-shaped things like crabstick.

Rolling transport: 6 piles with same size are placed under the base of the unit. Each roller must be a little longer than the base frame and suitable for the balance of the unit. (Figure 2-2)

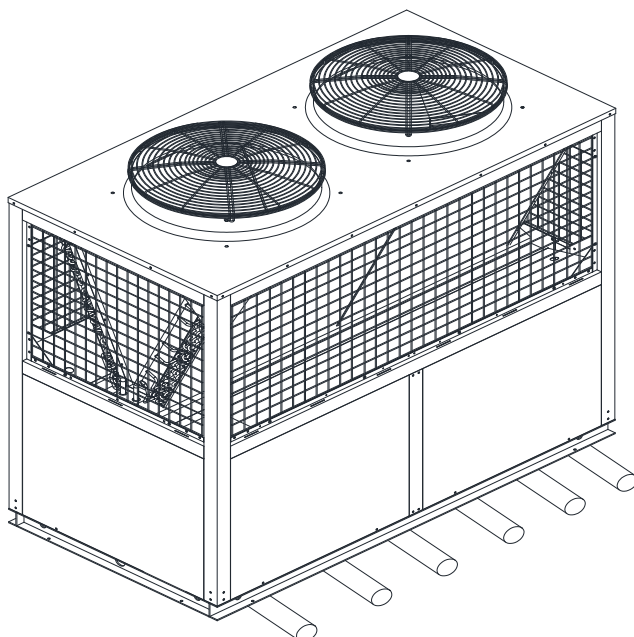

Figure 2- 2 Transport of the unit

Lifting & installation: (Figure 2-3) The strength of the lifting cable should be 3 times larger than the weight of the unit. Check and ensure that the lifting hook is fastened to the unit, and the lifting angle should be greater than 60°.

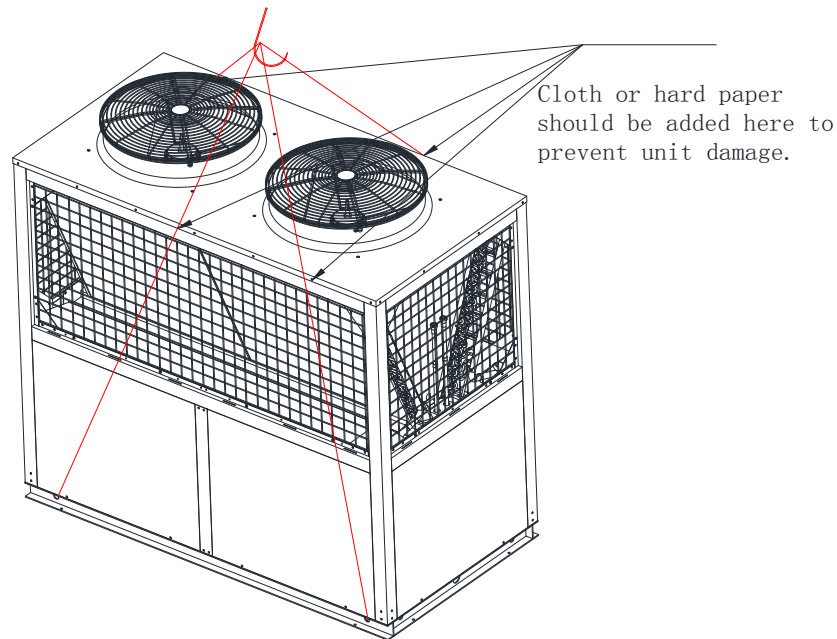

Figure 2- 3 Lifting of the unit

NOTE:

Do not stand under the unit when lifting.

Add fabric between the unit and the cable to prevent damage to the unit.

2.1.2 UNPACKING

Try to move the heat pump to the nearest place to the installation site, and then remove the packaging.

Unpacking steps:

1. Remove the side and top panels of cardboard.
2. Remove the packaging.
3. Remove the wood pallet.

2.1.3 INSPECTIONG

When receiving the goods of the company, please check that the delivery is complete and undamaged, and whether the quantity of accessories are correct and all of the accessories are undamaged. If any parts are missing or damaged during the inspection, please report to the carrier immediately. And if you find hidden damage, please report it to the local office of the carrier and product supplier.

2.2 SAFETY RULES

In order to achieve the design performance of the unit and maximize its service life, please strictly follow the installation instructions. This section should be applied in conjunction with current unit and electrical installation regulations.

The unit is installed in an integrated floor plan, please install it outdoors or on the roof of the building.

Before installing the equipment, confirm that the installation environment meets the requirements (as showed 1.6). And confirm the whether the building should be modified to match the construction of the pipeline, wiring and the ventilation ducts.

The installation must strictly follow the design drawings and reserve maintenance space. Refer to the engineering dimensional drawings provided by the manufacturer.

2.3 SAFETY PRECAUTIONS

- Please entrust professionals with professional knowledge to install. If it is installed incorrectly, it may cause fire, electric shock, injury, water leakage, etc.
- According to the law, reliable grounding work must be carried out. If the grounding work is not inadequate, it may cause electric shock.
- Do not put fingers, sticks, etc. into the tuyere. High-speed operation of the internal fan of the unit may result in damage to the unit or personal injury.
- When there is abnormality (such as burnt smell), should immediately turn off the manual power switch, stop the operation, and contact with the dealer. If continue to operate, it may cause electric shock or fire.
- When the unit needs to be moved or reinstalled, please ask professionals to operate. If the installation is not perfect, it may cause electric shock, fire, injury, water leakage, etc.
- DO NOT modify or repair the unit by user, otherwise it may cause electric shock or fire.
- When need repair the unit, please entrust professionals. if repaired improperly, it may cause fire, electric shock, injury, water leakage, etc.
- Confirm that the leakage protection switch is installed. The leakage protection switch must be installed, otherwise it may cause electric shock.
- Connect the cable correctly. If the cable is connected incorrectly, electrical parts may be damaged.
- DO NOT operate the unit near flammable materials (such as paint, paint, gasoline, chemical reagents, etc.) to prevent fire or explosion. If cause fire, should turn off the main power immediately and extinguish the fire with fire extinguishers.
- Regularly check and make sure that the erecting platform is secure and intact.
If the erecting platform is damaged and not strong, the unit may fall and cause casualties.
- When cleaning the unit, should cut off the manual power switch. If not, it may cause damage to the unit or personal injury.
- Do not touch the refrigerant exhaust parts by hand to prevent burns.
- Please use the corresponding fuse. It can not be replaced by copper wire or iron wire. Otherwise, the unit will be seriously damaged or fire.
- Do not spray flammable spray onto the unit, otherwise it may cause fire.

2.4 SELECTION OF INSTALLATION SITES

1. This outdoor unit is designed to be located outdoors with sufficient clearance for free entrance to the inlet and discharge air openings. The location must also allow for adequate service access.
2. The installation position of the unit should avoid the boiler flue or other air environment that will corrode the condensing coil and the metal parts of the unit.
3. If the unit is located in a location accessible to unauthorized personnel, isolation safety measures such as guardrails should be taken. This will prevent sabotage and accidental damage.
4. The bearing surface of erecting platform of the unit should be flat, can withstand the weight of the unit, can install the unit horizontally, and will not increase noise and vibration.
5. The operating noise and exhaust air of the unit should not affect neighbors.
6. There is no flammable gas leakage in the installation place of the unit.
7. Easy to carry out pipelines and electrical connections.
8. For occasions with special installation requirements, please consult the building contractor or architect or other professional.

 **NOTE:** Installation in the following locations may cause machine malfunction (if it cannot be avoided, please consult)

- In places where there is mineral oil such as cutting machine oil.
- In places where there is more salt in the air such as on the coast on the coast.
- In places where there are corrosive gases like sulfur gas in areas with hot spring.
- In places where the power supply voltage fluctuates severely.
- Outside the car or cabin.

- In places where is filled with oil such as in the kitchen .
- In places where there is a strong electromagnetic wave.
- In places where there are flammable gases or materials are present.
- In places where there is volatile acid gas or volatile alkaline gas.
- Other special environmental conditions.

2.5 REQUIREMENTS FOR THE ARRANGEMENT SPACING OF THE UNITS

Recommended installation spacing diagram for outdoor unit (unit: mm)

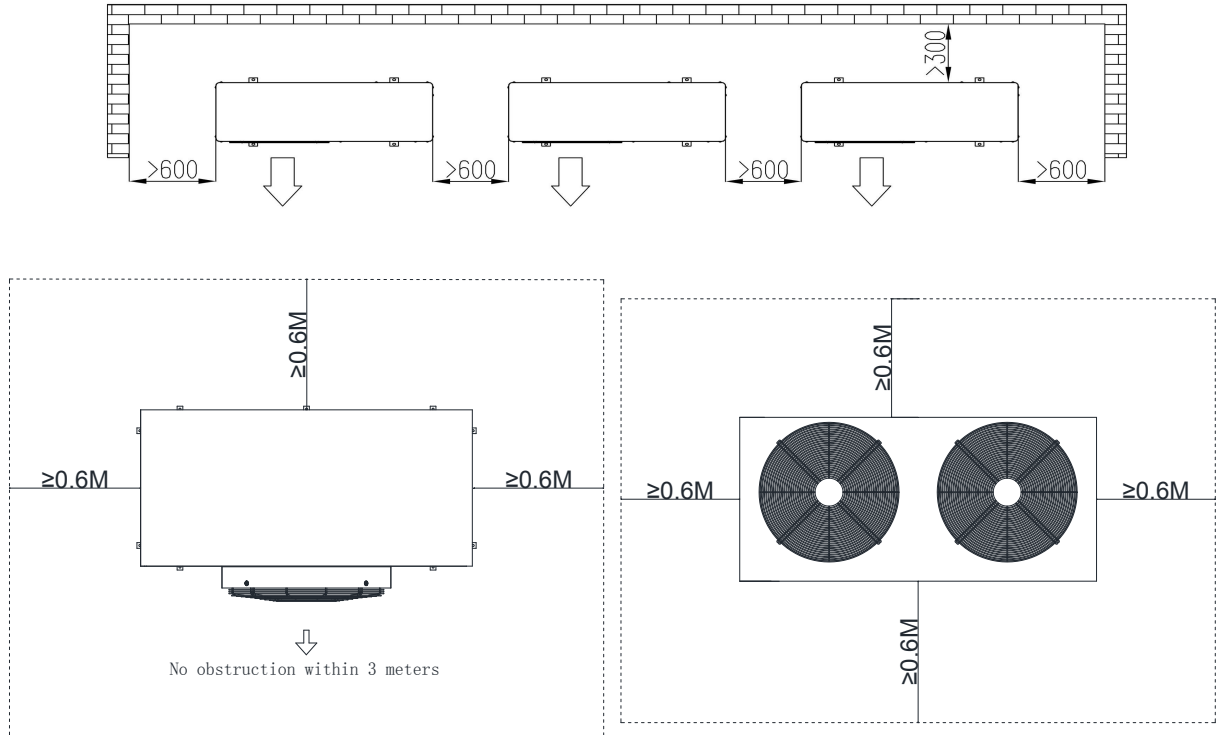

Figure 2- 4 Recommended installation spacing diagram for unit installation

NOTE:

- Required service & water pipes connection space when installing the unit.
- If there are obstacles in front of the air outlet of the unit, please make sure that the obstacles are more than 2000mm from the air outlet.
- If there are sundries around the unit, please make sure that the sundries are more than 400mm from the blow of the unit.
- The unit should not be installed in basements, indoors or other confined spaces. If the project requires the unit to be installed in such spaces, please consult with our company or the designated supplier.

2.6 SYSTEM INSTALLATION LAYOUT

2.6.1 OVERALL LAYOUT OF THE HYDRAULIC SYSTEM

The hydraulic system diagram of the household unit application is shown in the figure below.

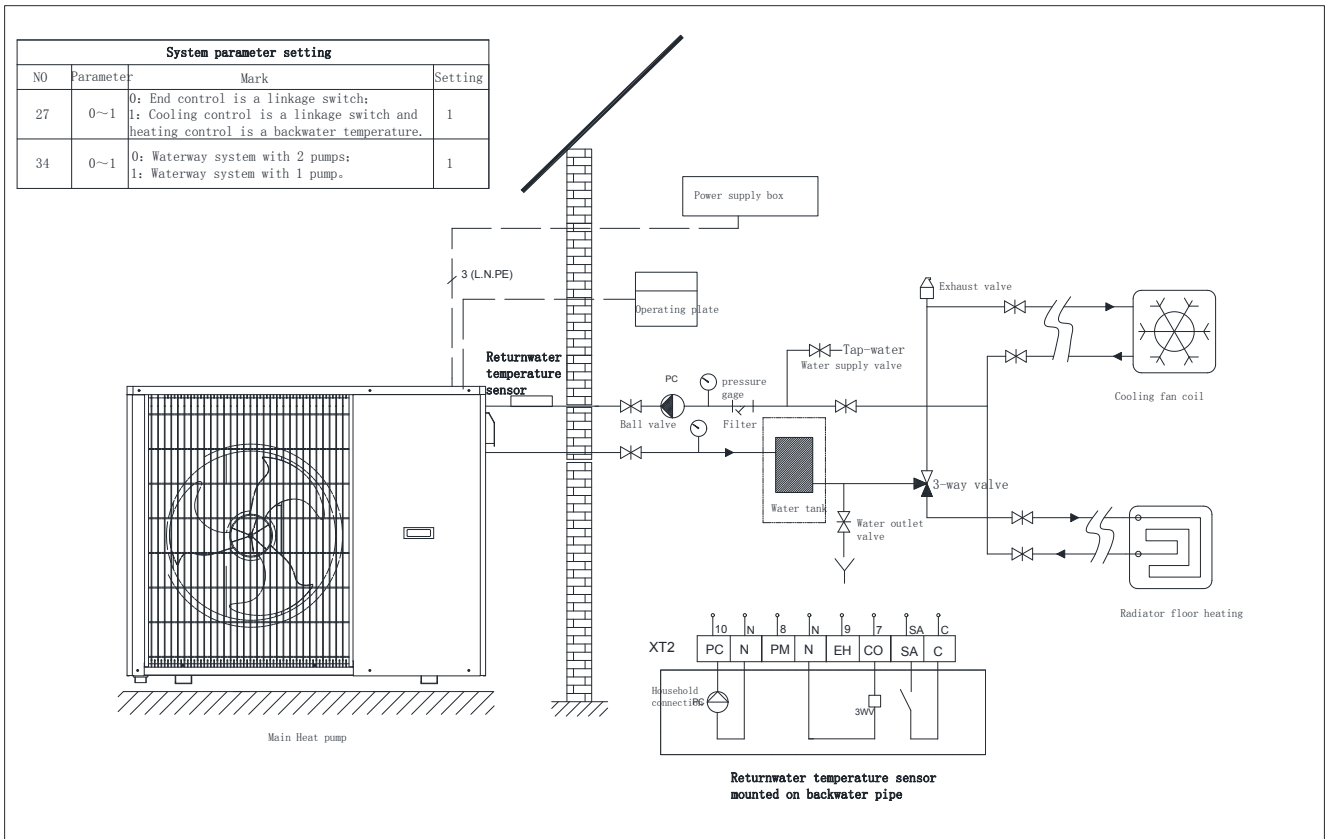

Figure 2- 5 Overall layout of single pump water system for household units

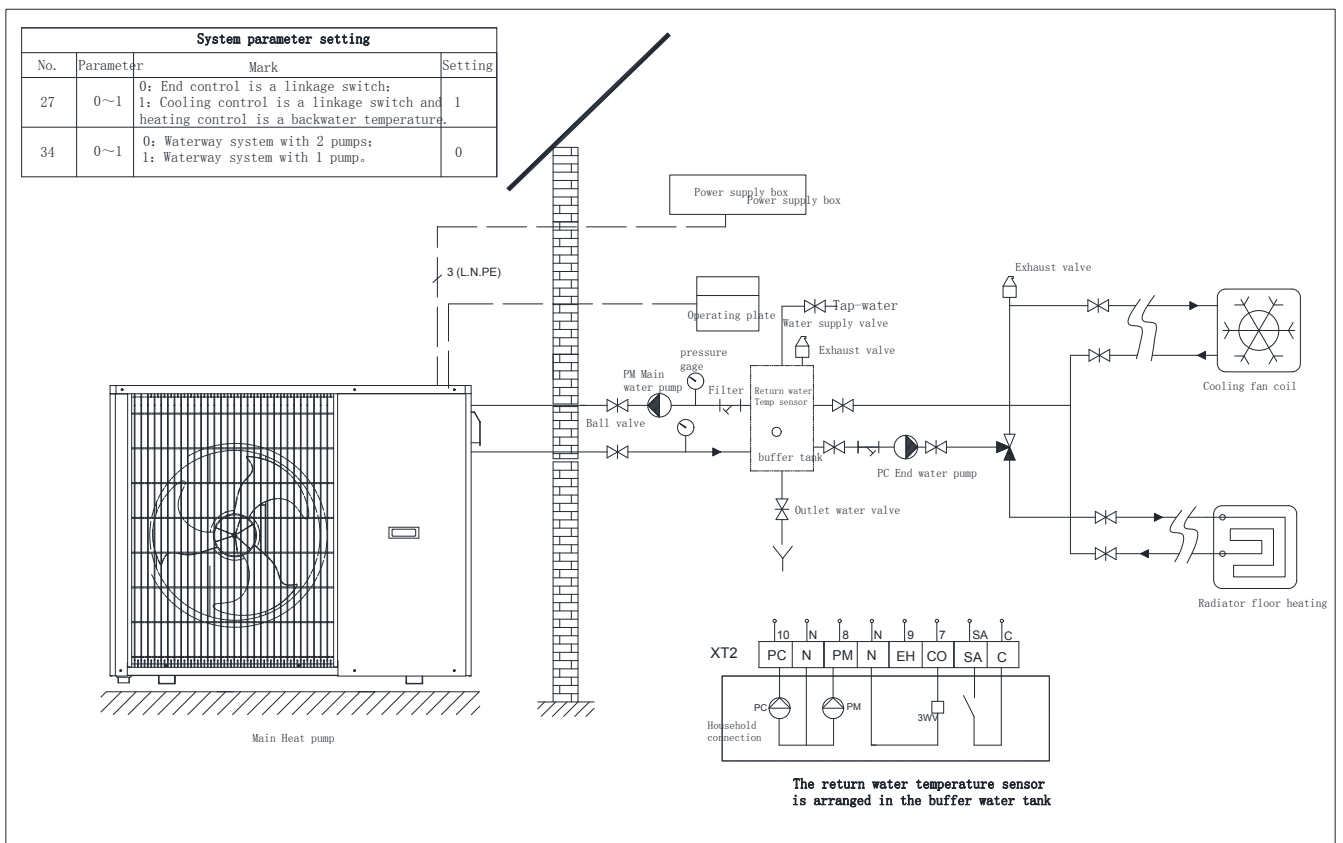

Figure 2- 6 Overall layout of the dual-pump water system for household units

After the piping of the circulating water system is completed, the air in the water system must be exhausted before starting the power;

In order to ensure that the resistance loss of the water system pipeline is not greater than the residual pressure outside the unit, please lay the water system pipeline by using the pipes which are in a bigger size than inlet & outlet of unit.

In order to prevent the unit from starting frequently due to the load being too small during operation, it is recommended that the user (who' terminal of unit is fan coil) install an accumulator tank to ensure that the system volume meets the minimum volume requirements of the system. Refer to Table 2-1 for the minimum volume of the water system.

In order to improve the cooling (heating) effect and save energy, the pipeline needs to be tightly insulated.

2.6.2 COMMERCIAL UNIT APPLICATION HYDRAULIC SYSTEM DIAGRAM

As shown in the figure

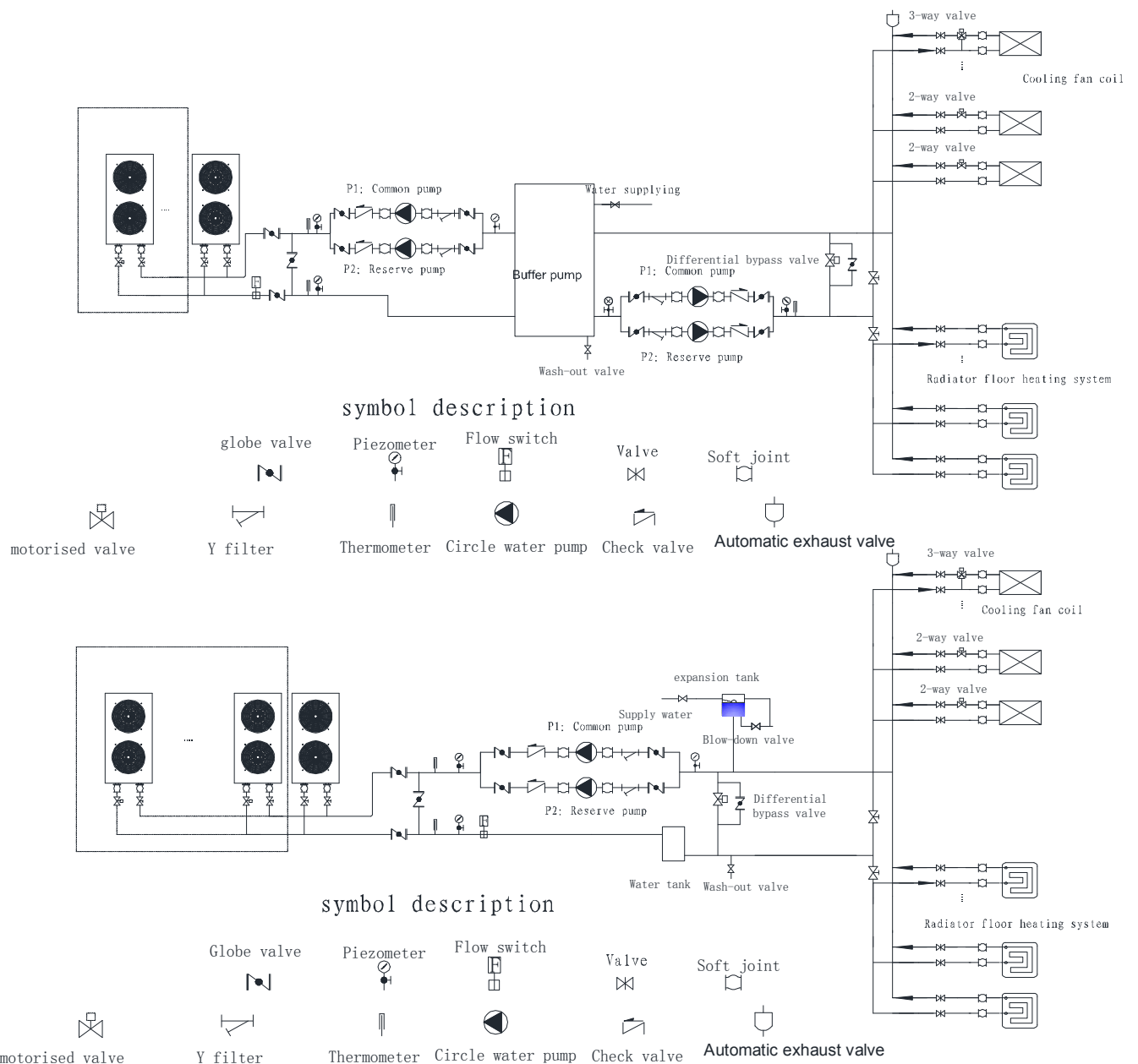

-
- 📖 The material of the expansion tank should be anti-corrosion and anti-rust. It must be installed at the highest point of the pipeline system to provide automatic exhaust and water capacity changes function.
 - 📖 After the piping of the circulating water system is completed, the air in the water system must be exhausted before starting the power;
 - 📖 An automatic exhaust valve must be installed at the highest point of the circulating water system;
 - 📖 The water flow switch is installed in a horizontal straight pipe section, which is more than 5 times the pipe diameter of the local resistance parts such as elbows and valves;
 - 📖 In order to prevent the unit from starting frequently due to the load being too small during operation, it is recommended that the user install an accumulator tank. For the calculation of the minimum volume of the water system, please refer to 2.6.3.
 - 📖 In order to improve the cooling (heating) effect and save energy, the pipeline needs to be tightly insulated.
-

2.6.3 MINIMUM CAPACITY OF THE WATER SYSTEM

For the household air conditioning water system, in order to obtain good thermal stability, the air conditioning load should be accurately determined first, and the host with matching installed capacity should be selected; Secondly, the greater the water capacity of the system, the greater the system cooling capacity, the better the thermal stability of the system. Conversely, the thermal stability of the system is worse. Therefore, when designing the water system, it should be checked whether the water capacity of the calculation system meets the thermal stability requirements of the system. When the actual water capacity of the system cannot meet the requirements, the system main pipe diameter or a new water storage tank should be increased. The system minimum water capacity can refer to the following recommended values:

Table 2-1 Recommended minimum volume table for water system

MODEL	Recommended minimum volume (L)
KFXFC-009SCI	100
KFXFC-014SCI	120
KFXFC-017SCII	130
KFXFC-018SCI	150

Because the floor heating capacity of the floor heating system is large, the system temperature stability is greatly guaranteed, and this point can be ignored.

For commercial water system design, it should be checked whether the water capacity of the calculation system meets the thermal stability requirements of the system. When the actual water capacity of the system cannot meet the requirements, the main pipe diameter of the system or a new water storage tank should be added. It is not means that the greater the water capacity of the system, the better the water capacity is. The water capacity is too large, and its thermal stability is undoubtedly good. However, after a long time of shutdown, time for pre-cooled or warm-up of the air conditioner will be extend.

The water capacity of the system can be calculated as follows:

$$V = P \times T / (C \times \Delta t)$$

V: system minimum (large) water capacity, kg (unit), 1 kg =1 L.

P: the heat dissipation power of the terminal of the unit, it can be calculated according to the rated cooling capacity of the host, W(unit).

T: Minimum (large) requirement for stability, S (unit);

C: Specific heat of water, 4200J/kg·°C;

Δt : The fluctuation of water temperature requirements, it can be referenced by 5K.

If you choose a KFXFC-065UI unit air conditioning, floor heating design as below:

If restart time should not less than 10 minutes, start the pre-cooling for 30 minutes.

Then it is recommended that the minimum volume of the water system is not less than $V = 53000 \times 60 \times 10 / (4200 \times 5) \approx 1514L$, which can be roughly calculated as the cooling capacity of 30L / kW.

And it is recommended that the maximum volume of the water system is no more than $V = 53000 \times 60 \times 30 / (4200 \times 5) \approx 4543L$.

Because the floor heating capacity of the floor heating system is large, the system temperature stability is greatly guaranteed, and this point can be ignored.

2.6.4 MECHANICAL PARAMETERS

Mechanical parameters as showed in the figure

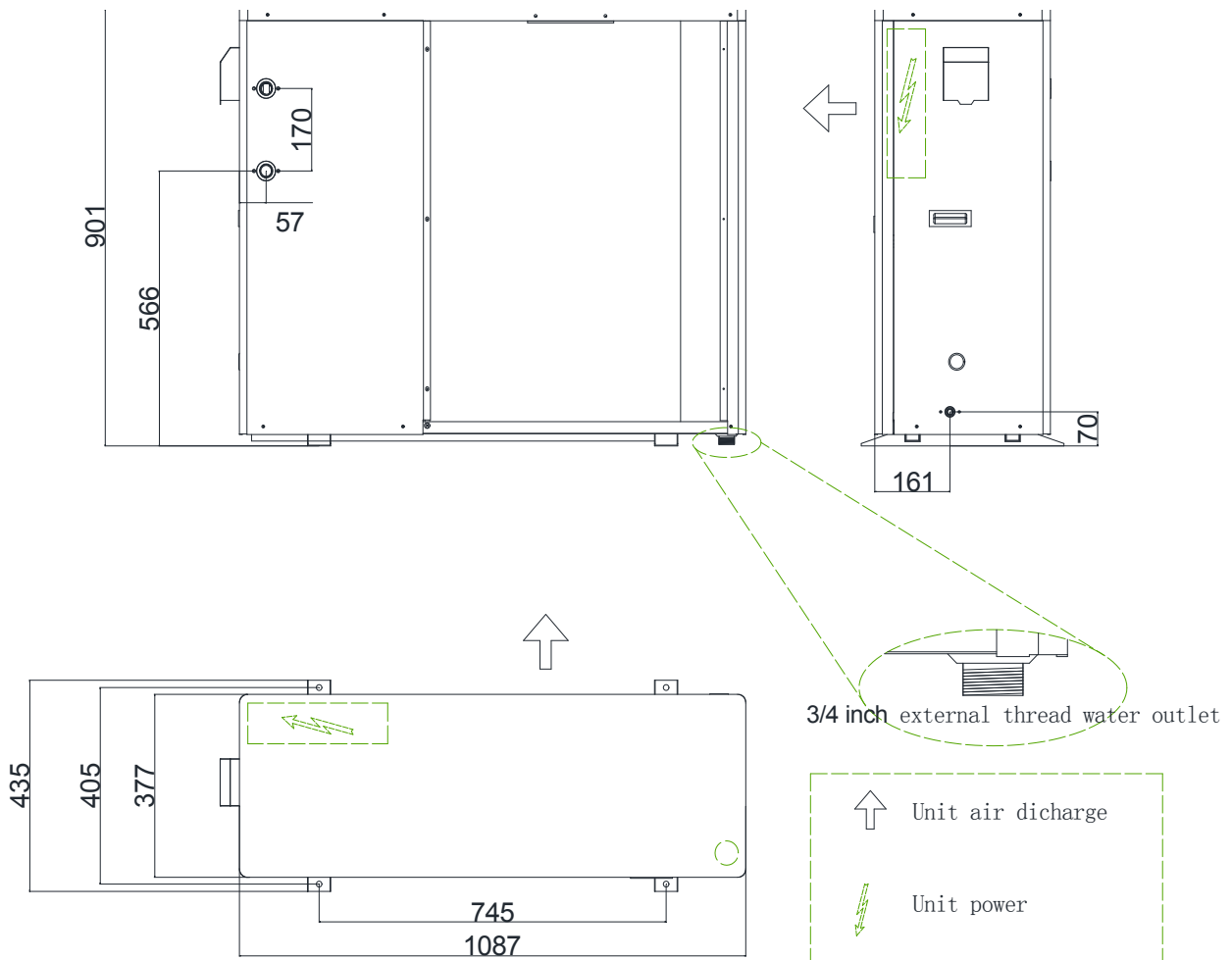

Figure 2- 7 Mechanical parameters of KFXF-009SCI Unit (mm)

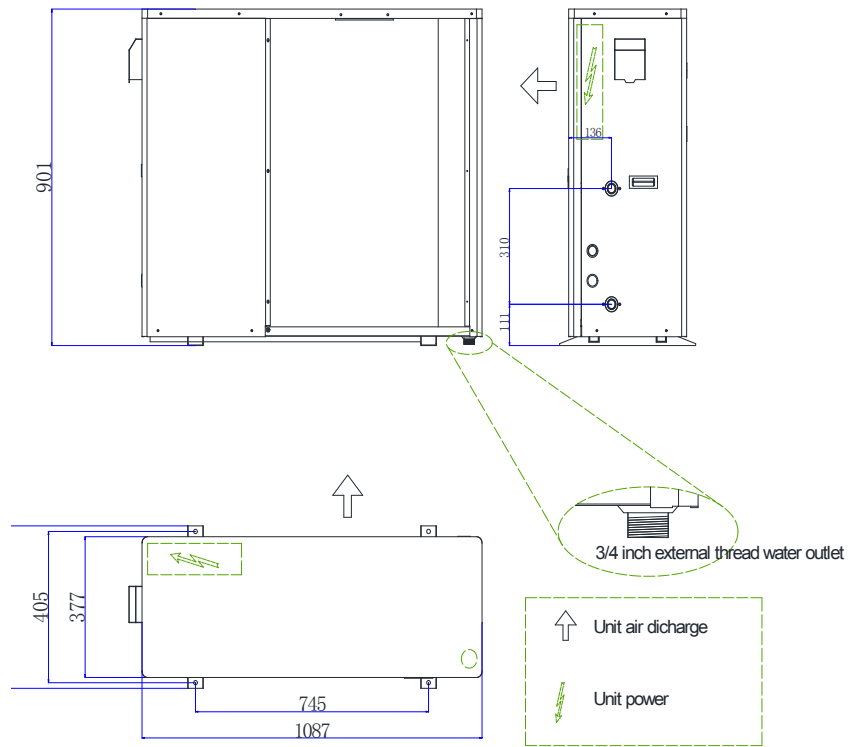

Figure 2- 8 Mechanical parameters of KFXF(C)-014SCI, 017SCII Unit(mm)

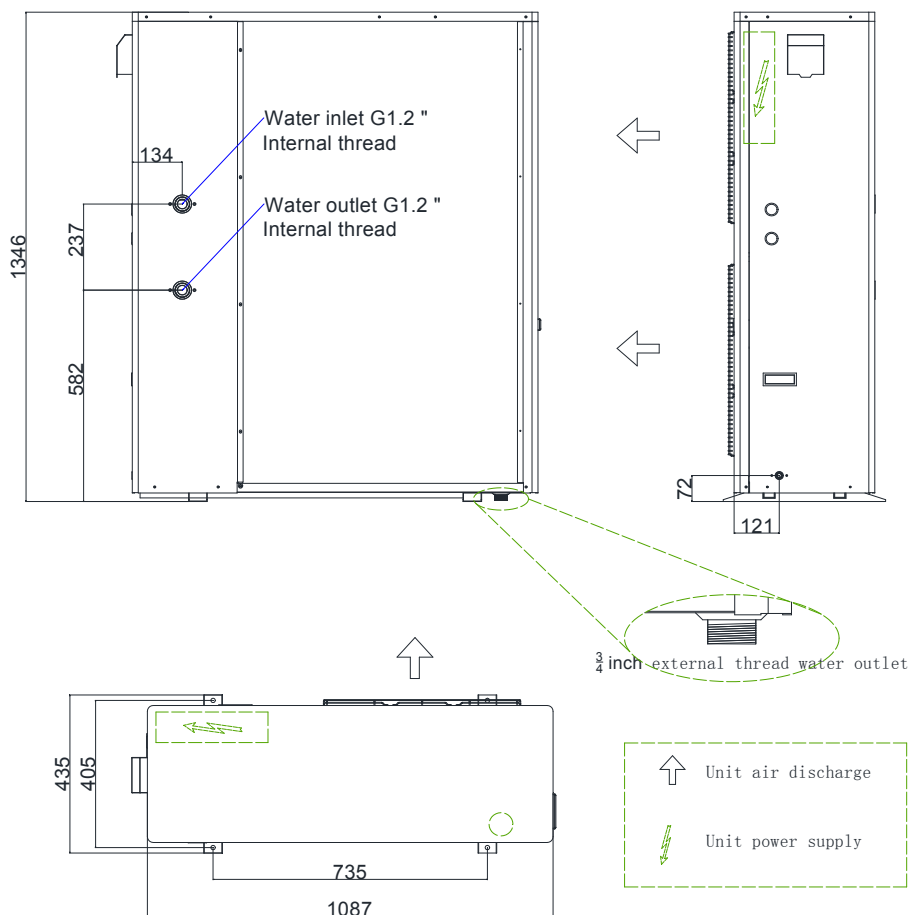

Figure 2- 9 Mechanical parameters of (D) KFXF(C) -014SCI, 017SCII Unit(mm)

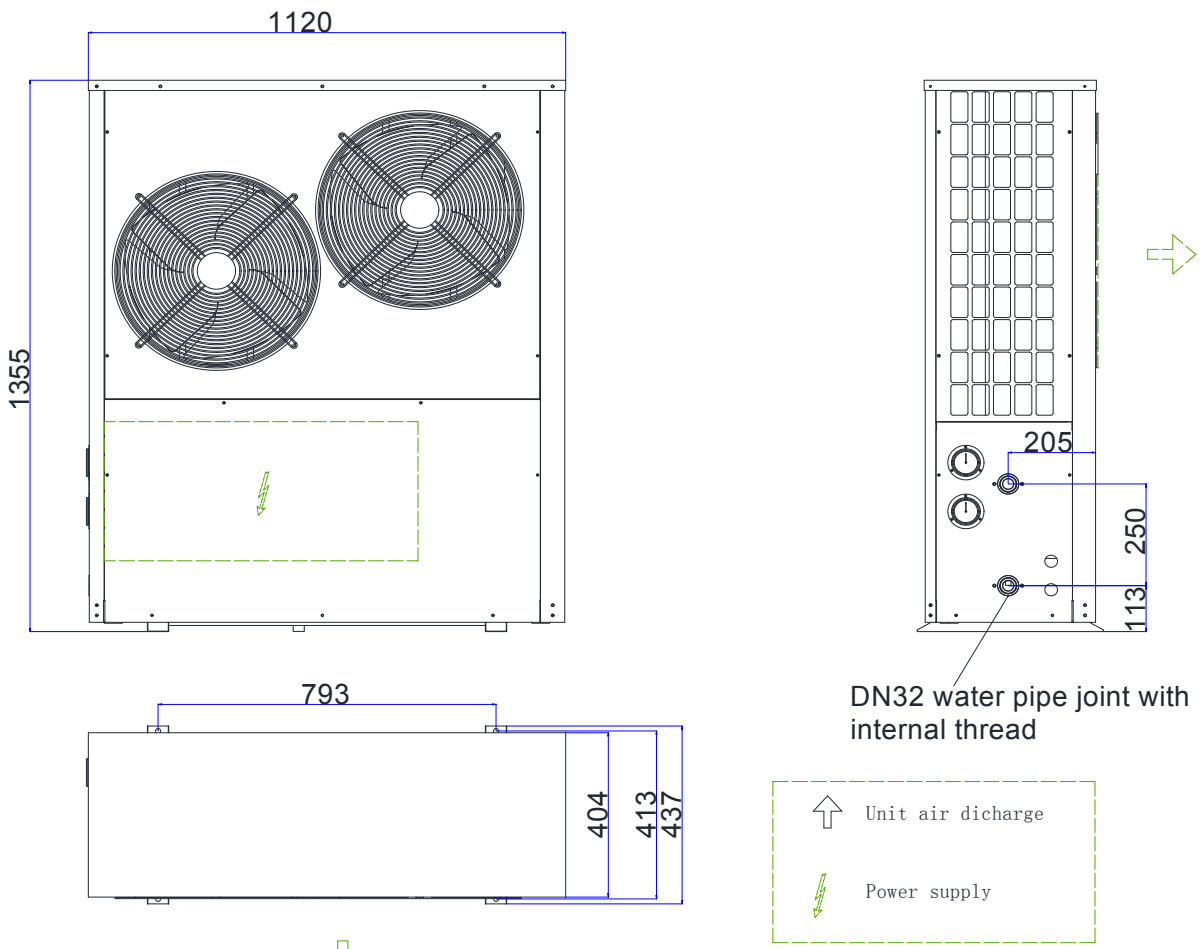

Figure 2- 10 Mechanical parameters of KFXF(C)-018SCI Unit(mm)

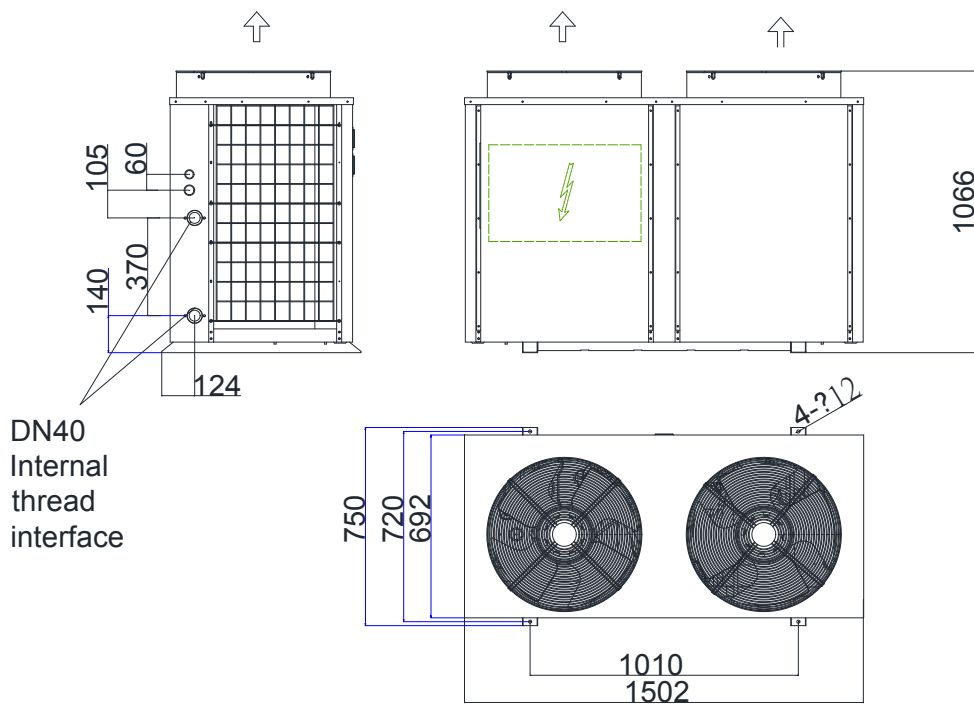

Figure 2- 11 Mechanical parameters of KFXF(C)-028UCII Unit(mm)

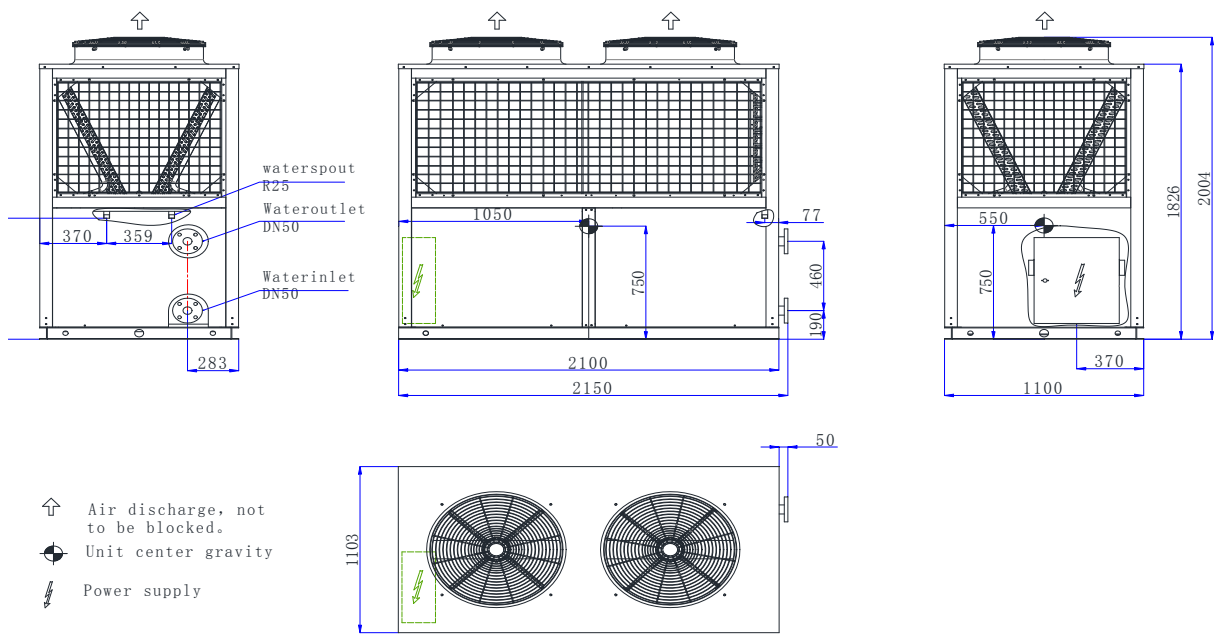

Figure 2- 12 Mechanical parameters of KFXFC-065UCII, 075UCII Unit(mm)

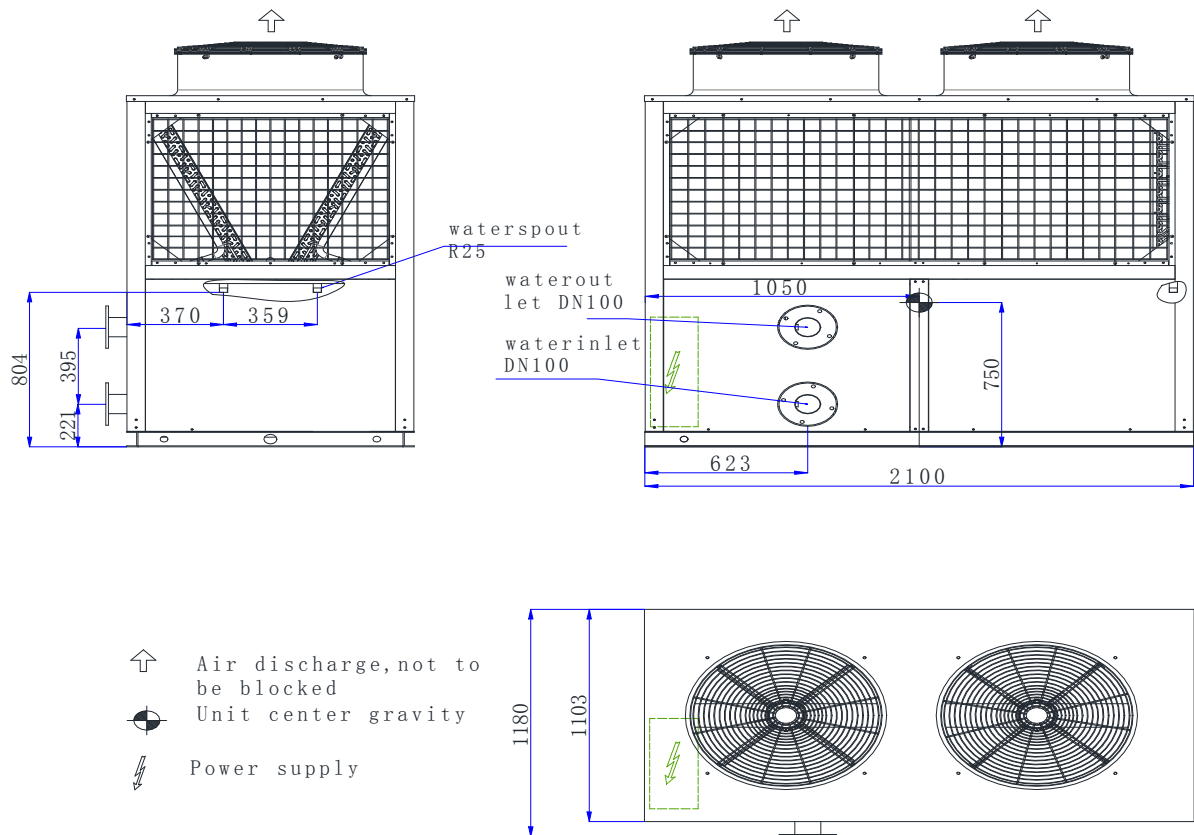

Figure 2- 13 Mechanical parameters of KFXF-065UCII, 075UCII Unit(mm)

2.7 INSTALLATION OF THE UNIT

2.7.1 INSTALLATION SPACE

NOTE:

Since the unit will produce condensed water, water leakage may cause damage to other equipment in the vicinity, so the drainage line must be provided at the installation site.

1. To facilitate installation and later tests and maintenance there must be sufficient free space around the heat pump;
2. Avoid placing multiple outdoor unit units together to avoid air flow crossover, load imbalance, and competitive operation;
3. When installing on the roof, should protect the waterproof layer and comply with local regulations.

2.7.2 MAINTENANCE SPACE REQUIREMENTS

1. There is no obstruction in front of the air outlet of the unit within 2m.
2. Maintenance space of 600mm or more is required on both sides of the unit.

2.7.3 INSTALLATION STEPS

The installation steps for the outdoor unit are as follows:

1. Make the mounting base according to the requirements of the following figures. The mounting base can be made by the user.

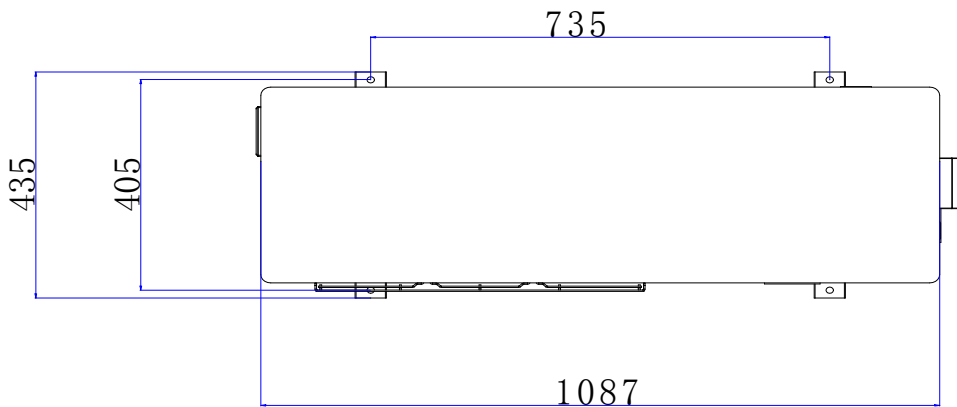

Figure 2- 14 Mounting base shape and size of KFXFC-009SCI, 014SCI, 017SCII Unit(mm)



Figure 2- 15 Mounting base shape and size of DKFXF(C) -014SCI, 017SCII, 018SCI Unit(mm)

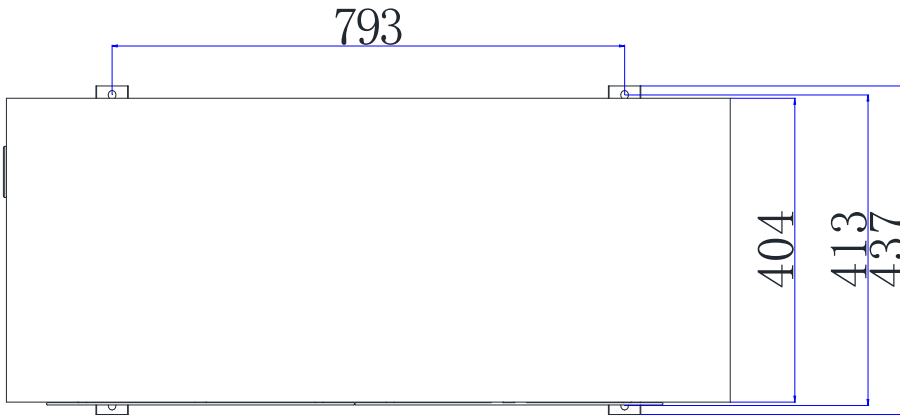

Figure 2- 16 Mounting base shape and size of KFXFC-018SCI

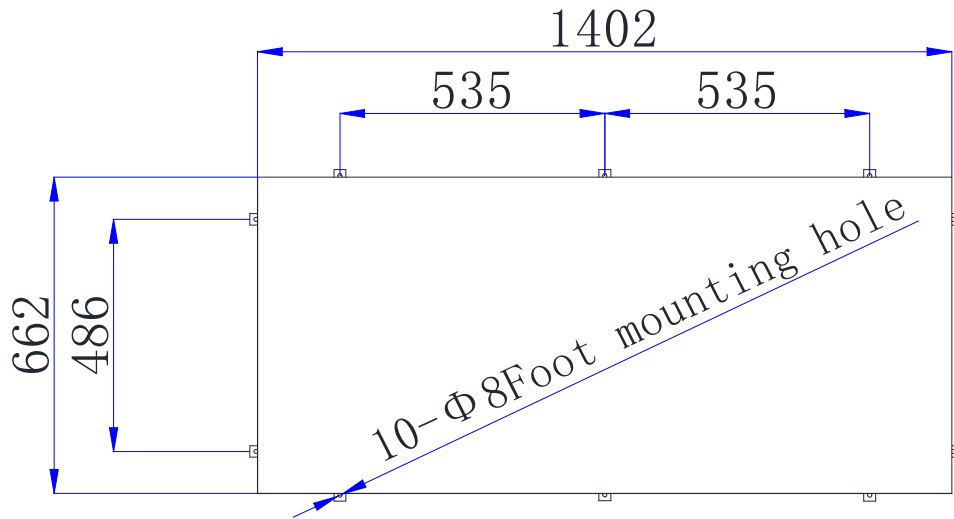

Figure 2- 17 Mounting base shape and size of KFXFC-032SCII

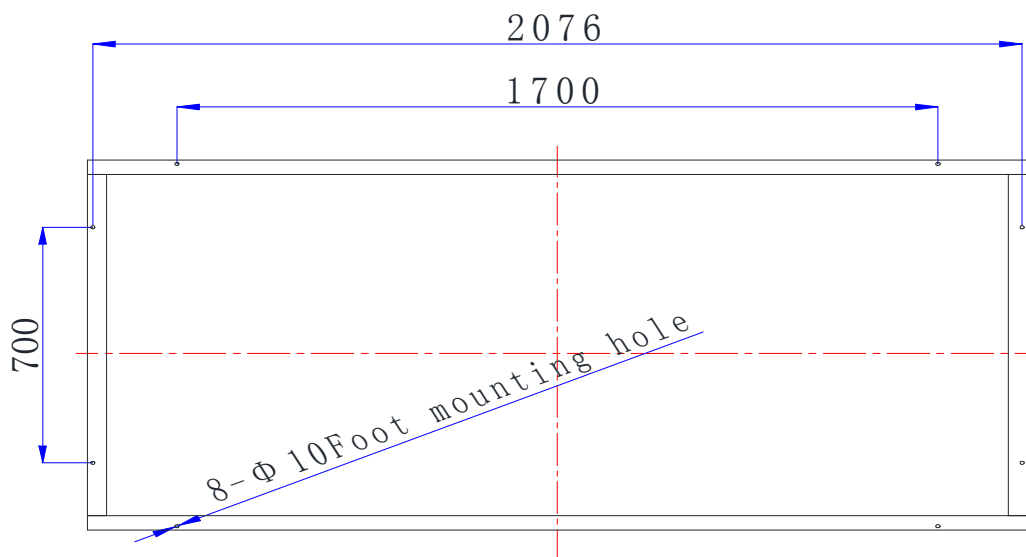

Figure 2- 18 Mounting base shape and size of KFXF(C)-065UCII, 075UCII

2. Determine the installation location and fix the mounting base to the selected installation location according to site conditions and user requirements.
3. Fasten the unit to the mounting base with nuts, spring washers, flat washers and bolts.
4. It can be slightly inclined to the drain side during installation to facilitate drainage.
5. Should be installed on a solid foundation.

2.8 INSTALLATION BASIC REQUIREMENTS

Inspect and ensure that the unit is installed on a solid, firmer and flat concrete foundation or metal steel frame, and should be have concrete around the foundation to prevent grass or other plants from obstructing the air circulation of the air-side heat exchanger. The following figure shows the installation base of the module unit (for reference). The installation base of each module is completely the same, and several space of adjacent modules must be kept above 60cm.

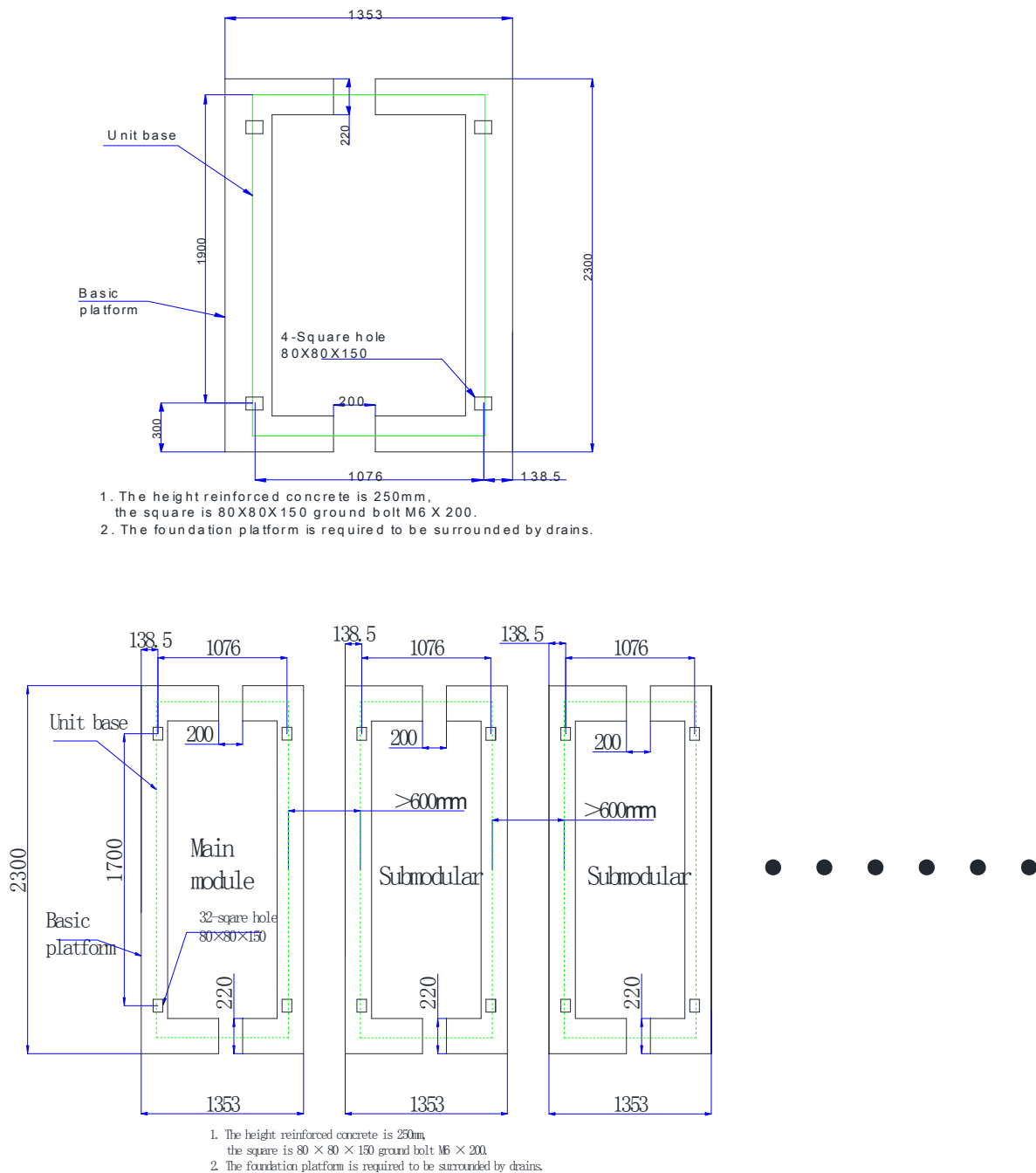

Figure 2- 19 Mounting base shape and size of modules

2.9 INSTALLATION OF THE UNIT PIPING

2.9.1 ABOUT CONNECTING THE UNIT WATER SYSTEM PIPING

About connecting the unit water system piping, please refer to the water system layout

2.10 INSPECTION ITEMS AFTER MECHANICAL INSTALLATION IS COMPLETED

1. Leave service space around the unit to facilitate equipment maintenance;
2. The unit is placed horizontally and the installed fastening parts are locked;
3. The pipe connecting to the unit has been installed and all valves have been fully opened;
4. The drain pipe is connected;
5. All pipe union joints are tightened;
6. After the installation of the unit, the sundries inside or around the equipment have been removed (such as transport materials, structural materials, tools, etc.).
7. After all contents have been checked and confirmed without errors, please perform electrical installation.

CHAPTER III ELECTRICAL INSTALLATION

This chapter describes the electrical installation of the unit, including task descriptions, installation precautions, connecting power cords, and installation checks.

3.1 TASK INTRODUCTION AND PRECAUTIONS

Lines that need to be connected at the installation site:

1. Power cable;
2. Output control line (OCL).

INSTALLATION PRECAUTIONS

- The unit should use a dedicated power supply, and the power supply voltage and frequency meet the rated specifications.
- The power supply circuit of the unit must have a grounding wire. The power grounding wire should be reliably connected to the external grounding wire, and the external grounding wire is effective.
- Wiring construction must be carried out by professional technicians in accordance with the electrical control wiring diagram.
- Wiring work must comply with the national electrical equipment technical standards, and set up leakage protection devices.
- The power cable and signal cable should be arranged neatly and reasonably, and should not interfere with each other, and should not be in contact with the connecting pipe or the valve body.
- After all the wiring construction is completed, it can be energized after careful inspection and confirmation.

The lines to be installed on the installation site including external power lines, controller lines, and unit connection lines. Once the unit is in place, the power cord and cable can be connected. All wires must be securely connected and must not be in contact with any moving parts. All wires must meet national or related manual standards. The unit must have grounding measures. All electrical equipment and its installation work must comply with national and local safety regulations. (Module circuit connection diagram)

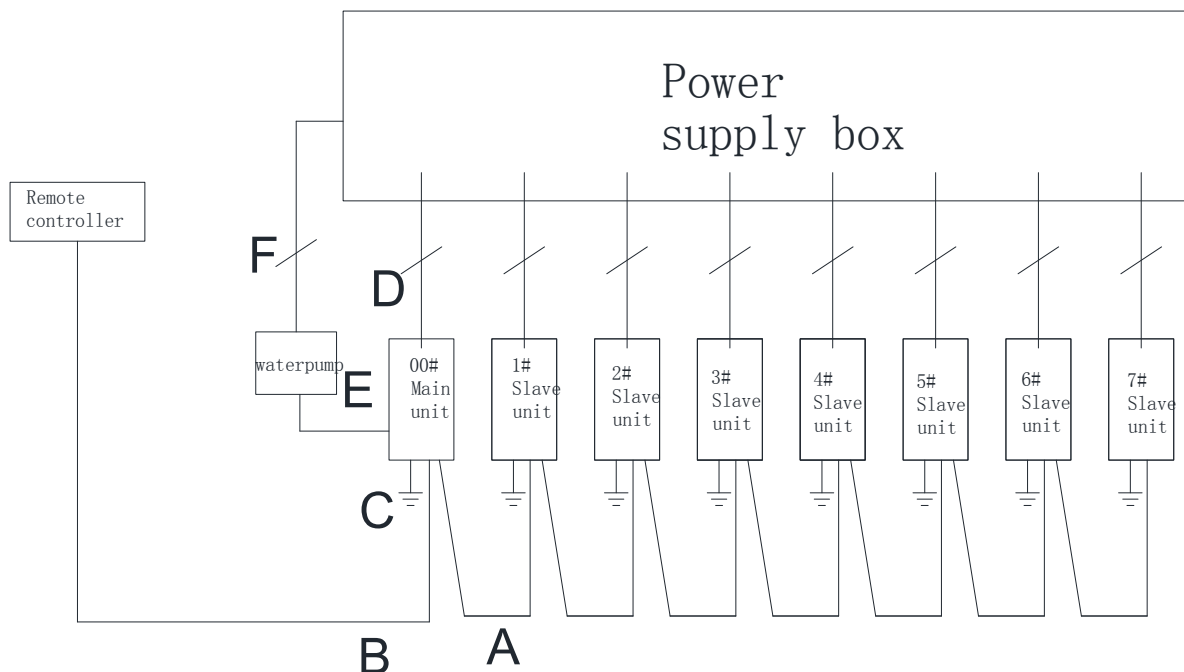

Figure 3- 1 Module circuit connection diagram

As showed in the Figure:

- A: Unit connection signal line (twisted shielded line)
- B: Connection signal line between unit and remote controller (four-core shielded cable)
- C: Unit ground wire
- D: Unit power line (three-phase four-wire)

NOTE: The communication line of the remote controller and the host control board should follow the principle of strong and weak power separation, avoiding power lines and other sources of strong electrical interference. Do not bundle with the power line. Do not install equipment that is too close to TV, audio, etc., to avoid interference and affect operation. Strong and weak wires are separated by at least 30cm.

3.1.1 POWER SPECIFICATIONS

POWER SPECIFICATIONS

It is recommended to use the copper core wire not smaller than the one listed in the table below.

Table 3-1

MODEL	KFXF (C) -009SCI	(D) KFXF(C)-014SI	(D) KFXF(C)-017SII
VOLTAGE/FREQUENCY	220V /1N~/50Hz		380V/3N~/50Hz
STATED CURRENT (A)	20	32	16
SECTION POWER WIRE (mm²)	4	6	2.5
(mm²)	2.5	4	1.5
MODEL	(D)KFXF(C)-018SI	(D) KFXF(C)-028SII	(D) KFXF(C)-032UII
VOLTAGE/FREQUENCY	220V /1N~/50Hz	380V/3N~/50Hz	
STATED CURRENT (A)	36	6	6
SECTION POWER WIRE (mm²)	6	4	4
SECTION GROUND WIRE (mm²)	4	4	4
MODEL	KFXF(C)-065UII		KFXF(C)-075UII
VOLTAGE/FREQUENCY	380V/3N~/50Hz		
STATED CURRENT (A)	65		65
SECTION POWER WIRE (mm²)	16		16
SECTION GROUND WIRE (mm²)	10		10

3.2 UNIT WIRING

3.2.1 WIRING REQUIREMENTS

1. The power supply and control lines that are not connected to the electrical control box are not allowed to pass through the electrical control box. Otherwise, electromagnetic interference may cause malfunction or even damage to the unit and control devices, and void the warranty.
2. There are generally strong electric lines passing through the electric control box, and 220V AC power is also passed on the control board. The wiring should follow the principle of strong and weak power separation. The operation panel cable cannot be bundled with the power cable.

3. All electrical wiring must comply with local wiring specifications. According to the Standards, users are responsible for providing voltage and current protection for the unit's input power.
4. All power supplies connected to the unit must pass a manual switch and ensure that when this switch is opened, the voltage on the unit's circuit node is completely removed.
5. The unit must be powered by the correct size cable. The unit should use an independent power supply. It is strictly forbidden to share the same power supply with other electrical appliances to avoid overload danger. The fuse or manual switch of the power supply should match the operating voltage and operating current of the unit.
6. The unit must be installed with a grounding wire. Do not connect the grounding wire to the gas fuel pipe, water pipe, lightning conductor or telephone ground wire. Improper grounding may cause electric shock. Please check the grounding of the unit for reliability frequently.
7. All the lines connected to the unit should prevent rainwater from penetrating into the unit to avoid leakage accidents.

3.3 PAY ATTENTION TO THE INSTALLATION CHECK

After the electrical installation is completed, it should be checked and confirmed:

1. The power supply voltage and frequency are the same as the rated voltage and frequency on the equipment nameplate.
2. There is no open circuit or short circuit in the system electrical circuit.
3. The power cable to the disconnect switch & the unit are connected with the grounding cable.
4. All cables and circuit connectors are tightened and the fastening screws are not loose.

 **NOTE:** The unit must be reliably grounded!

All of the above must be checked and confirmed without errors before you can start debugging.

3.4 SWITCH OF GROUND HEATING PANEL WIRES

In the actual application process, it is highly probable that heating and cooling use different terminal equipment. In this case, valve switching is needed to realize automatic switching between the two ends. In the water system, a three-way solenoid valve is used to switch the waterway. As shown below:

In the case of heating, the three-way valve is not electrified, and the terminal is applied to the floor heating.

In the case of heating. the three-way valve is electrified, and the terminal is applied to the wind disk.

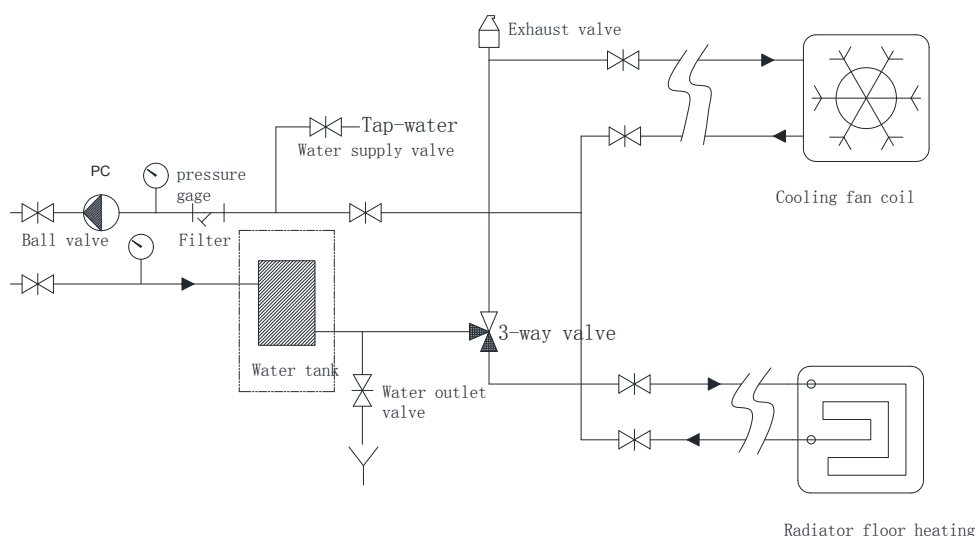

In conjunction with the cooling output port of the unit's electronic control function, this port will not output when in the heating mode, but will output in the cooling mode.

3.5 MODULE UNIT WIRING

3.5.1 MOTHERBOARD SECTION

1. Manually assign the unit number by dialing the DIP switches S2 and S1 on the main board as follows:

UNIT SEQUENCE	S2-1	S2-2	S1-1	S1-2	REMARKS
0	OFF	OFF	OFF	Unused	Host
1	ON	OFF	OFF	Unused	Slave
2	OFF	ON	OFF	Unused	
3	ON	ON	OFF	Unused	
4	OFF	OFF	ON	Unused	
5	ON	OFF	ON	Unused	
6	OFF	ON	ON	Unused	
7	ON	ON	ON	Unused	

The unit sequence 0 is the host, and the host shares the air conditioning return water temperature sensor and linkage signal through the centralized control line. Units 1~7 are slaves, and the slaves do not need air conditioning return water temperature sensors and linkage signals.

2. HARDWARE CONNECTION

- 2.1 Connect all the unit cables that need to be controlled (A-A, B-B of the connection interface).
- 2.2 The line controller is only connected to the main control board of the host.

CHAPTER IV SYSTEM TEST RUN

This chapter introduces the system test run of the unit, including the preparation of the mechanical, water system, electrical and other parts before starting the machine.

4.1 IMPORTANT INFORMATION OF TEST RUN

- Test operation can be carried out after electrical safety inspection.
- Do not block the air inlet and outlet. Otherwise may result in reduced unit performance or can not work due to activation of the protective device..
- Confirm that all valves are open, flush the sewage in the water system pipeline, and confirm that the water quality cleanliness meets the requirements.
- Fill the water system with water and empty the air to ensure that there is no air in the water system.
- DO NOT perform forced operation. (If the protective device does not work, it may cause damage to the unit and void the warranty!).
- Whether the system is fully warmed up (more than 12 hours).

4.2 POST-INSTALLATION CHECK ITEM LIST

According to this manual, check the installation work with reference to the following table.

Table 4-1 Installation work check item list

CHECK ITEM LIST	SPECIFIC DESCRIPTION	YES	NO
Whether the installation location meets the requirements	The unit is firmly installed on the foundation and leveled		
	Air side heat exchanger air flow space meets requirements		
	Maintenance work space meets requirements		
	Appearance meets requirements		
Whether the water system meets the requirements	Water pipe size meets requirements		
	Pressure control meets requirement		
	Insulation meets requirements		
	Water system has no air		
Whether the electrical system and wiring meet the requirements	Leakage protector is effective		
	Ground wire is connected correctly		
	Wire capacity meets requirements		
	Switching capacity meets requirements		
	Safety device capacity meets requirements		
	Voltage and frequency meet the requirements		
	Connection position fastening		
	Safety device meets requirements		
Operator panel connection meets requirements			

4.3 TEST RUN

1. Control the unit operation by the operation panel, and check the following items according to the operation instructions:

2. Whether the operation panel switch normal.

3. Whether the function keys of the operation panel are normal.

4. Whether the indicator light normal

5. Whether the drainage normal

6. whether the temperature difference between the inlet and outlet water is normal (4 ~ 7 ° C)

7. Whether the vibration and sound during operation are normal.

8. Whether the wind, noise and condensate generated during operation affect neighbors

9. Whether there is refrigerant leakage.

 **NOTE:** When restarting after shutdown, the unit has a protection function, and the compressor will be delayed for 3 minutes.

CHAPTER V OPERATING INSTRUCTION

This chapter describes the use of the operation panel. The specific contents include the panel LCD screen description, panel button description, operation instructions, parameter query and other interface operation instructions.

5.1 DIGITAL THERMOSTAT OPERATION

The appearance of the remote controller and the function of the buttons

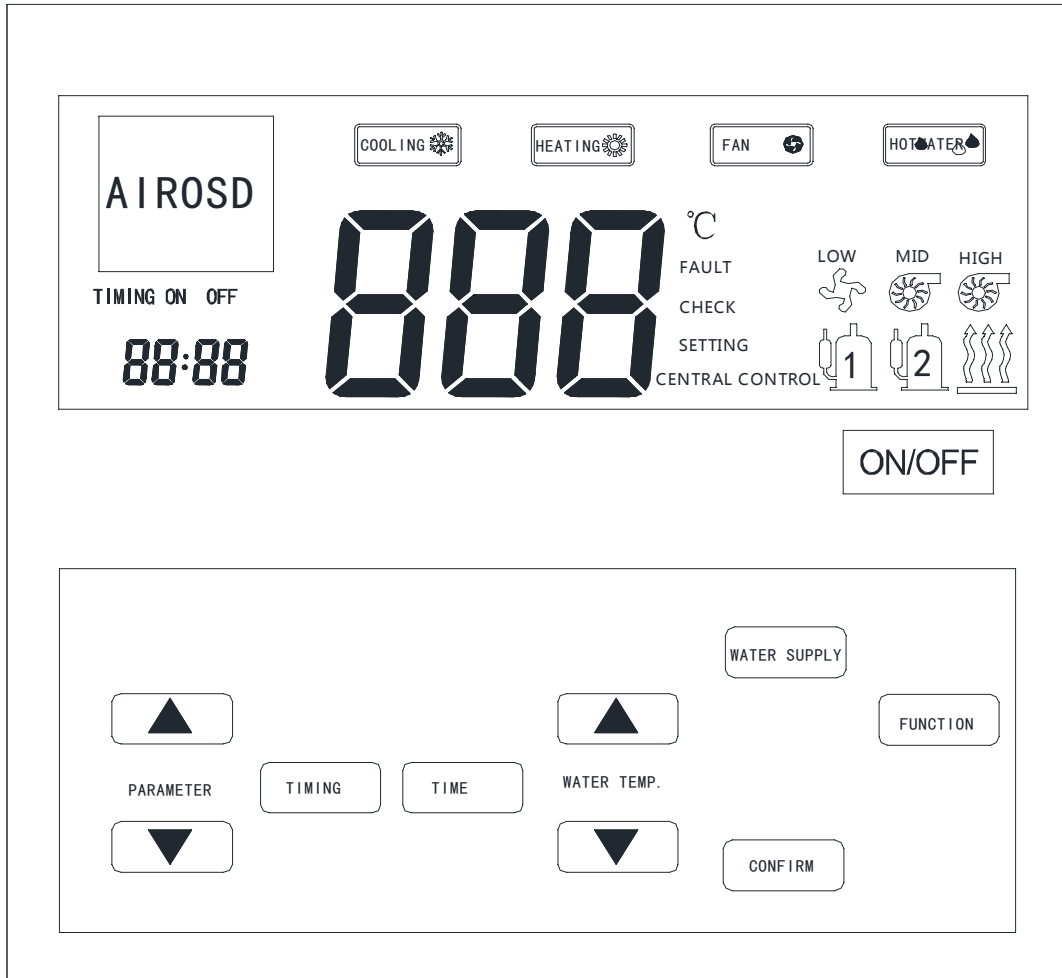

5.1.1 HIGH, MID, LOW

This display shows no meaning in non-domestic hot water machine models

5.1.2 COOLING, HEATING, FAN, HOT WATER

When "COOLING" is lit, it indicates that the air conditioner is in the cooling mode, and when it is flashing, it indicates that the air conditioning cooling mode has been activated;

When "HEATING" is lit, it indicates that it is in the air conditioning heating mode, and when it is flashing, it indicates that the floor heating mode has been activated;

When "FAN" is lit, it indicates that the system enters the defrost mode;

"HOT WATER" is meaningless in the absence of a domestic hot water machine.

5.1.3 COMP. 1, COMP. 2.

When “COMP. 1 (Compressor 1)” is lit, it indicates that the compressor 1 has been started.

When “COMP. 2 (Compressor 2)” is lit, it indicates that the compressor 2 has been started.

When  is lit, it indicates that the auxiliary electric heating has started.

5.1.4 FAULT

When the FAULT flashes, it indicates that the unit is faulty. However, if the time of locks is not reached, the fault code will not be displayed in the main temperature display position, and the fault code can only be queried in the query parameter 01. If the time of lock is reached, the main temperature display position will display the fault code.

CODE	NAME	REMEDY
0	Phase text	Check the 3-phase input power cable and re-adjust the phase.
2	Water flow protection	Check whether there is water in the water supply pipe for water, replace the water flow switch.
3	High pressure 1	Check the cable and replace the high voltage switch.
4	Low pressure 1	Check the cable and replace the low voltage switch.
7	High pressure 2	Check the cable and replace the high voltage switch.
8	Low pressure 2	Check the cable and replace the high voltage switch.
9	Communication failure	Check the cable. If the motherboard indicator flashes, replace the communication cable and panel. Otherwise, replace the motherboard.
10	Probe of coil 2	Check the cable and check if the probe temperature is accurate. Replace the probe
11	Probe of coil 1	Check the cable and check if the probe temperature is accurate. Replace the probe
12	Air probe	Check the cable and check if the probe temperature is accurate. Replace the probe
13	Water probe	Check the cable and check if the probe temperature is accurate. Replace the probe
15	Return air probe	Check the cable and check if the probe temperature is accurate. Replace the probe
16	Probe of exhaust 1	Check the cable and check if the probe temperature is accurate. Replace the probe
17	Probe of exhaust 2	Check the cable and check if the probe temperature is accurate. Replace the probe.
20	Temperature protection of exhaust 1	Check whether the probe temperature is accurate, replace the probe
21	Temperature protection of exhaust 2	Check whether the probe temperature is accurate, replace the probe
26	Cooling low temperature protection	The outlet water temperature is less than 1 degree protection
46	Return air temperature 1	Check the cable and check if the probe temperature is accurate. Replace the probe
47	Return air temperature 2	Check the cable and check if the probe temperature is accurate. Replace the probe
98	Wrong match	The program version of the motherboard and panel is different. Replace the motherboard or panel.

5.1.5 CHECK

After entering the internal parameter query mode, the "CHECK" will light up.

5.1.6 SETTING

When you enter the parameter setting function, “SETTING” will light up.

5.1.7 CENTRAL CONTROL

The "CENTRAL CONTROL" will be illuminated when the linkage switch is closed.

5.1.8 MAIN DISPLAY

The main display consists of 3 digits and 8 segments of LCD digital. It displays temperature values and values based on different states.

5.1.9 TIMING ON & TIMING OFF

When "TIMING ON", "TIMING OFF" are lit, it indicates that the timing function has been activated. If "TIMING ON" is flashing, it means that it has entered the automatic timing start mode. If "TIMING OFF" is flashing, it means that it has entered the automatic timed shutdown mode.

5.1.10 SUB DISPLAY

The sub display consists of 4 digits and 8 segments of LCD. Display time and code, code number, etc. according to different environments.

5.1.11 FANS & PUMPS

When  is lit, it indicates that there is a system fan running.

When  is lit (blue color), it indicates that the end pump is running.

When  is lit (red color), it indicates that the unit pump of the main pump runs.

5.2 FUNCTIONAL OPERATION INSTRUCTIONS

5.2.1 ON/OFF

Press the "ON/OFF" button to change the state of the switch. In the OFF state, the main display area of the unit is not displayed, and the main display area of the main unit displays the current inlet water temperature when in the ON state.

5.2.2 WATER SUPPLY

This button is meaningless in non-domestic hot water machine models.

5.2.3 WATER TEMPERATURE SETTING

Enter the cooling or heating temperature setting according to the setting mode;

The parameters can be queried and set in the system query and setting state.

Press the water temperature "▲/▼" button in the standby mode to enter the water temperature setting mode. After entering, press "▲/▼" to adjust the temperature. After the adjustment is completed, press "Enter".

5.2.4 TIMING

Press and hold the "TIMING" button for more than 4 seconds in the standby mode to force enter the forced defrost mode, but it should meet the defrost condition.

Within 30 seconds of power-on, press and hold the “TIMING” button for more than 4 seconds in the power-off state to force enter the debug mode. In the debug mode, the terminal of pump is forcibly output, and the water flow detection is normal, but not limited. Re-power off mode. Re-power off and exit this mode.

Press this button to set the time period.

5.2.5 TIME

Press the “TIME” button to enter the clock setting.

Press this button to set the time period.

5.2.6 PARAMETER QUERY

In the standby mode, press the parameter “▲/▼” button to enter the parameter query function. After entering, press the parameter “▲/▼” to change the data, press the water temperature “▲/▼” button to convert data group 0 and data group 1. The specific parameters are as follows:

CODE	FUNCTION DESCRIPTION	CODE	FUNCTION DESCRIPTION
0-01	Error code	1-01	Undecided
0-02	Setting mode	1-02	2#Return air
0-03	Set model	1-03	Outlet temperature of economizer 2
0-04	Unused	1-04	Outlet temperature of economizer 2/1#Return air
0-05	Temperature of coil 1	1-05	Inlet temperature of economizer 1
0-06	Air temperature	1-06	Outlet temperature of economizer 1
0-07	Temperature of effluent water	1-07	Undecided
0-08	Temperature of return air	1-08	Undecided
0-09	Temperature of water tank	1-09	Undecided
0-10	Temperature of exhaust 1	1-10	Undecided
0-11	Temperature of exhaust 2	1-11	System 1: open level/2
0-12	Undecided	1-12	System 2: open level/2
0-13	Customer number of panel	1-13	Customer number of motherboard
0-14	Main program version of panel	1-14	Main program version of motherboard
0-15	Modification version number of panel	1-15	Modification version number of motherboard
0-16	Unused	1-16	Undecided
0-17	Status of communication quality	1-17	Running mode

5.2.7 FUNCTION

Press this button in the off state to switch the heating and cooling mode.

Press and hold the “FUNCTION” button for more than 4 seconds in the standby mode to enter the normal parameter setting function. After entering, press the parameter “▲/▼” to set the data. Press the "OK" button to enter or exit and save the set parameters. Press “Confirm” to enter the rear panel display will flash, and then press the water temperature “▲/▼” button to set the corresponding parameters. The specific settings are as follows:

CODE	FUNCTION	SET VALUE RANGE (DEFAULT)	UNIT	CODE	FUNCTION	SET VALUE RANGE (DEFAULT)	UNIT
0	Useless		°C	21	Antifreeze running time	255~1(5)	Minute
1	Refrigeration temperature	7~30(12)	°C	22	Antifreeze interval time	255~1(30)	Minute
2	Heating temperature	20~55(40)	°C	23	Unused	Unused	Unused
3	Unused	Unused	Unused	24	Unused	Unused	Unused
4	Electric environment temperature	-9~5(-5)	°C	25	Heated back temperature	7~2(5)	°C
5	Defrost start temperature	5~-9(-3)	°C	26	Hot water compensation temperature	7~0(2)	°C
6	Defrost end temperature	15~-5(8)	°C	27	Terminal control method	1~0(1)	
7	Unused	Unused	Unused	28	Phase sequence detection	3~0(0)	
8	Unused	Unused	Unused	29	Panel offline mode	1~0(1)	
9	Unused	Unused	Unused	30	EXV control switch	1~0(1)	
10	Unused	Unused	Unused	31	Unused	Unused	Unused
11	Unused	Unused	Unused	32	Unused	Unused	Unused
12	Exhaust protection temperature	120~90(120)	°C	33	Unused	Unused	Unused
13	Unused	Unused	Unused	34	Water system mode	0~1 (1)	
14	Unused	Unused	Unused	35	Unused	Unused	Unused
15	Unused	Unused	Unused	36	Unused	Unused	Unused
16	EXV control target value	7~-2(1)	K	37	Unused	Unused	Unused
17	EXV correction coefficient	20~5(5)	K	38	Time setting		
18	Overheat adjustment time	60~30(30)	S	39	Host timing setting		
19	Defrost interval time	90~10(60)	Minute	40	Unused		Unused
20	Defrost running time	15~2(10)	Minute				

REMARKS:

1. Cooling temperature: backwater control temperature value when cooling, backwater temperature \leq set value, the unit stops working;
2. Heating temperature: backwater control temperature value when heating, backwater temperature \geq set value, the unit stops working;
3. Electric environment temperature: when the ambient temperature is lower than this set value, the auxiliary electric heating output;
4. Defrost related parameters: relevant parameters of unit defrost operation;
5. EXV related parameters: electronic expansion valve control related parameters;

6. Antifreeze related parameters: antifreeze operation parameters of unit;
7. 27 terms: Terminal control mode: 0: The unit is completely controlled by the two-way interlocking signal. When the option is 0, the port is closed, the end pump runs, the port is disconnected, the pump stops running; when the option is 1, the unit is cooled. When the unit is controlled by the two-way interlocking signal to control the end water pump, the unit starts and stops by the return water temperature when the unit is heating, and the pump determines the opening and closing time according to the ambient temperature;
8. Phase sequence inspection: When this value is 0, the unit does not detect the phase sequence, and when it is other values, the phase sequence is detected;
9. Panel offline mode: 0: the motherboard is prohibited to run without a panel, 1: the motherboard allows to run without a panel;
10. 34 terms water system operation modes. When this value is 1, only one water pump is applied. The hydraulic system application mode is shown in Figure 2-3. When this value is 0, the dual water pump are applied, the hydraulic system application mode is 2-4. .
11. A). Time-related mode: Press the parameter “▲/▼” to add or decrease by hour. Press the water temperature “▲/▼” button to add or subtract minutes.
 B). Timing setting: "TIME" button to convert 3 time periods. The main display area shows the current setting period (1, 2, 3)
 The "TIMING" button can be used to sets and changes the set time of the query timing on and off when querying the status. In the setting mode, it is used to set the timing on, off and time off.
 Check timing time and status. Press the “TIMING” button to set the time for setting the timer on and off. If there is no time display, it means that the timing function of this time period is not enabled. If this time period is enabled, the corresponding timed on and off time will be displayed.
 C). Start “TIME” timing function. After entering the timing setting function, press the "CONFIRM" button and the screen will flash. Press the “TIMING” button to set the timed on time setting, the time off time setting and the time period time off setting. When the timed on time is set, the “TIMING ON” will light up. When the timed off time is set, the “TIMING OFF” will light up. When the time is set and the time is closed, press the "CONFIRM" button to save the time and open the timing functions of the time period.
 D). Turn off the time period function. After entering the timer time setting, press the timing button 3 times. At this time, the screen is flashing, but the “TIMING ON” and “TIMING OFF” lights are not on. Press the "CONFIRM" button to turn off the timeout function.

Turn off all timers, long press the “FUCTION” button for 3 seconds, turn off all timers, default host and hydration startup status.

For example: host time period 1, setting example: timed opening time 15:45 timed off time: 20:30

Press and hold the “FUCTION” button (4 seconds) in standby mode >> Enter the setting interface (clock display 01, temperature display hot water setting temperature) >> Press the parameter “▼” button twice (3 “compressor” symbols are on, number “1” on the temperature position is indicate “TIME” 1). At this time, in “CHECK” state>> B1, set the current time period >> A1. Set the time off >> C1

(A1) Press the "CONFIRM" button, the “timed on” and the “default time” flash. Press the parameter “▲/▼” buttons separately increase and decrease the hours, press the temperature “▲/▼” buttons to add or subtract minutes. After setting the power-on time, press the "TIME" button to switch to the setting OFF. At this time, the timing off and the default time flash, press the “▲/▼” buttons to increase and decrease hours. Press the “▲/▼” buttons to add or subtract minutes. After the setting is finished, press "CONFIRM" to save.

(B1) When the time period is started, the "TIMING ON" or the "TIMING OFF" will not flash, and the corresponding time is also displayed. Press the "TIME" button to switch the time of checking timing on or the time off. If it is not displayed, the timing of the time period has not been enabled.

(C1) Press the "CONFIRM" button to enter the timing setting, "TIMING ON" and the default time flash, then press the time button twice, "TIMING ON" and "TIMING OFF" are not lit, and the time window displays "OFF". Press the "CONFIRM" button can be used to turn off the time period.

5.2.8 CENTRALIZED CONTROL DESCRIPTION

1. Set the number of online connections. Enter the correct password in the shutdown state, you can modify the online number setting of parameter 07. Minimum value 1, maximum value 8.
2. Each unit parameter query conversion, standby state according to the water temperature up and down keys to convert the unit serial number. For example, the time display area shows IP01, indicating that the current data query status of unit serial number 1.
3. The fault display shows that when a certain unit fails, it is automatically changed to the display status of the faulty unit.

CHAPTER VI SYSTEM OPERATION AND MAINTENANCE

This chapter describes the system operation and maintenance of the unit.

6.1 SYSTEM DIAGNOSTIC TEST

6.1.1 ELECTRONIC CONTROL PART

ELECTRICAL MAINTENANCE

Inspect and handle the electrical connections according to the following items.

1. Complete electrical insulation test: Find unqualified contacts and handle them. The cutouts of control parts or the air switches should be on disconnect state during the test to avoid damage to the control panels by high voltage;
2. Statically check whether the contact of each contactor is flexible and has no jamming;
3. Dust off electrical and control components with a brush or dry compressed air;
4. Check whether the contacts of the contactor contacts with arcing or burning marks. Replace it if needed;
5. Tighten the electrical connection terminals;
6. Check that whether the plug-in quick connector is in good contact. If it is found to be loose, replace the terminal.

CONTROL MAINTENANCE

Perform visual inspection, simple function detection, and handling the control section according to the following items.

1. Check the appearance of the power transformer and isolation transformer, and detect the output voltage of them;
2. Check that it the surface of the control interface board, display control board, sensor board, etc. with aging phenomenon.
3. Clean dust and dirt on each electrical control component and control panel by brush and electronic dust remover;
4. Check and tighten the output and input plug interfaces of the control interface board, including the connection between the display control board & the control interface board, and the connection between the control interface board & the temperature-humidity sensor board;
5. Check the connection between the user terminal and the control interface board;
6. Check the output connection of the control interface board to each contactor & to the input connection of the fan overload protector & to high and low voltage switch, etc. Should focus on inspection high-low voltage switches and electronic expansion valves, etc.. If any loose or poor contact occurs, replace them immediately;
7. Replace electrical components such as control panels that have been tested for problems;
8. Check the specifications and aging of the power connection, and replace the connection if necessary;

6.2 COOLING SYSTEM

Parts of the refrigeration system must be inspected monthly to see if the system is functioning properly and if there are signs of wear. Unit failures usually occur before the device fails or damage, therefore periodic inspections are the primary means of preventing most system failures. When the refrigeration system fails, the fault can be judged according to some parameters of the system operation.

6.2.1 PLATE HEAT EXCHANGER

Brazed plate heat exchanger has self-cleaning function thanks to the high-strength turbulence in the channel of it. However, in some applications fouling is more likely to occur. For example when the water is hard water with high temperature. In this case, it is necessary to use a circulating flushing device to clean the heat exchanger. Pump

weak acid -- 5% phosphoric acid or 5% oxalic acid (If the heat exchanger is frequently cleaned) into the heat exchanger and clean it.

Plate cleaning is not included in the company's maintenance, if necessary, you can consult the company's service personnel.

6.2.2 COMPRESSOR REPLACEMENT

WARNING

When changing the compressor, you must avoid touching the refrigerant and lubricating oil. If touched, it can cause severe skin burns or frostbite. Long-sleeved gloves must be worn when handling contaminated parts.

Build-in high efficiency scroll compressor in the system with high reliability. If the construction carry out strictly in accordance with the correct procedures, the probability of failure during operation is very low.

Compressor motors rarely burn out due to insulation failure. In the events that the motor is indeed burnt out, most of them were caused by not good mechanical or not good lubrication, namely, high temperature overheating.

If problems that could cause compressor failure can be detected and corrected early, most compressor failures can be avoided. Maintenance personnel regularly perform maintenance inspections on situations in which abnormal operation may occur. Instead of replacing them after a compressor failure, it is better to take necessary steps to ensure proper system operation. It is not only more easier but also the cost will be more lower.

When diagnosing the compressor, check that all the electrical components of the compressor are functioning properly:

1. Check all fuses and circuit breakers;
2. Check the operation of high pressure switches and low pressure switches;
3. If the compressor fails, find out that the compressor failure is caused by electrical faults or mechanical faults.

MECHANICAL FAULTS

The mechanical failure of the compressor cannot be judged by smelling the burning odor. Try rotating the motor and if a mechanical fault is confirmed, the compressor must be replaced. If the motor burnt out, correct the factors that cause the motor to burn out and clean the system. It should be noted that the compressor motor burnout is usually caused by improper cleaning of the system.

ELECTRICAL FAULT

Electrical faults can be judged by a noticeable pungent odor. In the event of a severe burn, the oil will turn black and acidic. In the event of electrical failure and the refrigeration compressor motor is completely burned out, measures must be taken to clean the system to eliminate acid in the system and to prevent such failures in the system.

NOTE:

Damage of compressor replacement parts which caused by improper cleaning, according to the applicable warranty is not binding.

When the compressor is completely burned, replace the compressor and replace the filter, and check the throttling components. If there is a fault, it should be replaced. Before the replacement, the cleaning system is necessary. If the cleaning method is not clear, please consult our professional and technical personnel.

PROCEDURE FOR REPLACING THE COMPRESSOR

Cut off the power;

Connect the interface of the pressure gauge to the needle valve on the suction pipe for refrigerant recovery;

NOTE:

The refrigerant must be recycled or disposed of in accordance with relevant regulations. The release of refrigerant into the atmosphere is harmful to the environment and is illegal.

4. Remove the electrical connection to the compressor;
5. Loosen the nozzle on the suction and exhaust ports of the compressor;
6. Remove the faulty compressor;

7. If the compressor is completely burned, the refrigeration system piping should be cleaned and the filter should be replaced;

 **NOTE:**

The new compressor should not unplug the rubber plug of the suction and exhaust ports too early. The compressor without plug in the air should no more than 15 minutes to prevent the compressor from absorbing water and bringing it to the system.

8. Install the new compressor in place and connect the pipe nozzle. Connecting electrical lines;

9. Vacuum the system and add refrigerant; the vacuuming time is more than 60 minutes, and the vacuum should be kept more than 10 minutes. After ensuring normal of the vacuum, the refrigerant can be added according to the rating plate parameters.

10. Power on the system according to the normal startup debugging process, and check whether the system running parameters are normal.

CHAPTER VII FAULT FINDING and REMEDIES

This chapter describes fault finding and remedies.

 **NOTE:**

Some electronic circuits have lethal high voltage and only allow the technician to perform maintenance operations on the unit. Special care must be taken when doing fault finding for electrification.

The fault diagnosis and treatment of each component are shown in Table 7-1

Table 7-1 Troubleshooting the compressor and refrigeration system

MESSAGE	CAUSE	REMEDY
PHASE LOSS OR REVERSE PHASE	Phase loss; Reverse phase.	Checked on the 3 phase current source of the unit; Reverse the 2 phase power lines.
WATER FLOW SWITCH DISCONNECTED	Insufficient water flow; Circulating inlet pipe has air; Circulating pump; Water flow switch is damaged.	Clean the Y-type filter and increase the water flow; Exhaust the air from the circulating inlet pipe; Check the circulation pump and capacitor and repair it; Replace the water flow switch;
HIGH PRESS ERROR	Inadequate water flow; The system is blocked, and the inlet temperature sensor is off; High voltage switch is damaged.	Increase water flow; Check and repair the system, properly fix the inlet temperature sensor and replace the high voltage switch.
LOW PRESS ERROR	Low voltage switch is damaged; Not enough anti-freeze in the coolant system; The evaporator is clogged or the fin surface is dirty.	Replace the low voltage switch; Fill the refrigerant with the correct percentage of anti-freeze; Remove the blockage or clean the evaporator fins.
EXHAUST PIPE TEMPERATURE OVERHEATING	Insufficient refrigerant; The system is blocked.	Test for leaks and add refrigerant according to parameters; Check system troubleshooting.
COMMUNICATION ERROR	Loose interface between the operation panel and the motherboard; Signal line disconnection;	Check the interface between the operation panel and the motherboard and reinforce it; Replace the signal line.
SENSOR FAILURE	The interface between the sensor and the motherboard is loose; Probe of sensor is off; Sensor cable turn-off or shorted; Sensor damage	Check the interface between the sensor and the motherboard and reinforce it; Re-fix the transmitter probe; Repair the sensor cable; Replace the sensor.

UNIT NOT RUNNING	Electricity failure; The power supply wiring of the unit is loose; The unit power fuse is blown.	Check the power to ensure that the power is qualified. Reinforce the connection of power supply; Replace fuse wire.
PUMP RUNNING BUT WITHOUT WATER FLOW	The relevant valve is not open; The air run into the water system; Y type filter is dirty	Open the relevant valve; Excluding air from the water system; Cleaning the Y filter.
LOW CREW CAPACITY	Insufficient refrigerant; Not good insulation of water system; The evaporator is clogged or the surface of the fin is dirty; Y type filter is dirty.	Test for leaks of system, repair it and charging refrigerant according to parameters; Strengthen the insulation of the water system; Remove the blockage or clean the evaporator fins; Cleaning the Y filter
THE COMPRESSOR IS NOT RUNNING	Electricity failure; Loose connection wiring; Damage to the compressor contactor; Compressor overheating and overload protection.	Check the power supply to ensure that the power is qualified; Reinforce the power wiring; Replace the compressor contactor; Find out the cause of overheating and troubleshoot after booting
COMPRESSOR OPERATION NOISE IS LARGE	Liquid refrigerant enters the compressor; Compressor internal parts are damaged.	Check if the expansion valve is invalid; Replace the compressor.
THE FAN DOES NOT WORK	The fan set screw is loose; The fan motor burned out; Start capacitor failure; Fan contactor is damaged.	Reinforce the set screw; Replace the motor; Replace the capacitor; Replace the contactor.
THE COMPRESSOR IS RUNNING BUT NOT HEATING	The refrigerant is completely leaked; Compressor failure.	Test for leaks of system, repair it and charging refrigerant according to parameters; Replace the compressor.

NOTE:

If these instructions are not followed during installation, operation and maintenance AIROSD Heat Pumps' liability according to the applicable warranty is not binding.

CO₂ ↓
Reduce CO₂



FOSHAN AIROSD THERMAL TECHNOLOGY CO.,LTD

Add.: AIROSD Building, Dongfeng Road, Nanhai area, Foshan city, Guangdong province, China

Tel.: 0086-(0)757-81796616

Fax: 0086-(0)757-81796613

Website: www.airosd.com

